

MACHINE SCREWS

Class 2A — Stainless Type 18-8

Threads #00-80 thru 1/4-20

Lengths 1/8" thru 1"

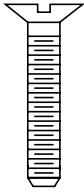

THREAD	LENGTH A	CATALOG NUMBER
		BASIC NUMBER + SCREW TYPE
#00-96	1/8	SE00-12 — A, B, C or E
	3/16	SE00-18
	1/4	SE00-25
	5/16	SE00-31
	3/8	SE00-37
#0-80	1/8	SE0-12 — A, B, C, D or E
	3/16	SE0-18
	1/4	SE0-25
	5/16	SE0-31
	3/8	SE0-37
#2-56	1/2	SE0-50
	3/16	SE2-18 — A, B, C, D or E
	1/4	SE2-25
	5/16	SE2-31
	3/8	SE2-37
#4-40	1/2	SE2-50
	3/16	SE4-18 — A, B, C, D or E
	1/4	SE4-25
	5/16	SE4-31
	3/8	SE4-37
#6-32	1/2	SE4-50
	5/8	SE4-62
	1/4	SE6-25 — A, B, C, D or E
	5/16	SE6-31
	3/8	SE6-37
#8-32	1/2	SE6-50
	5/8	SE6-62
	3/4	SE6-75
	1/4	SE8-25 — A, B, C, D or E
	5/16	SE8-31
#10-24	3/8	SE8-37
	1/2	SE8-50
	5/8	SE8-62
	3/4	SE8-75
	1	SE8-100
#10-32	1/4	SE01-25 — A, B, C, D or E
	5/16	SE01-31
	3/8	SE01-37
	1/2	SE01-50
	5/8	SE01-62
1/4-20	3/4	SE01-75
	1	SE01-100
	1/4	SE11-25 — A, B, C, D or E
	5/16	SE11-31
	3/8	SE11-37
1/4-20	1/2	SE11-50
	5/8	SE11-62
	3/4	SE11-75
	1	SE11-100
	1/4-20	1/4
5/16		SE21-31
3/8		SE21-37 — A, B, C, D or E
1/2		SE21-50
5/8		SE21-62
1/4-20	3/4	SE21-75
	1	SE21-100

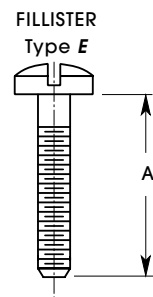
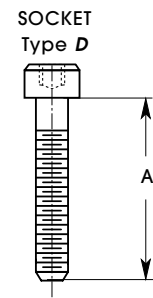
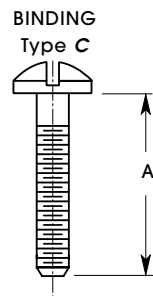
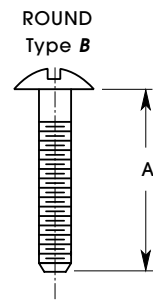
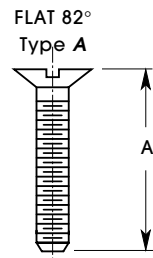

MACHINE SCREWS

Class 2A — Stainless Type 18-8
 Threads #0-80 thru 1/4-20
 Lengths 1/8" thru 1"

LONG-LOK®
 NYLOC®
 Machine Screws

THREAD	LENGTH A	CATALOG NUMBER
		BASIC NUMBER + SCREW TYPE
#0-80	1/8	SE0N-12 — A, B, C, D or E
	3/16	SE0N-18
	1/4	SE0N-25
	5/16	SE0N-31
	3/8	SE0N-37
	1/2	SE0N-50
#2-56	3/16	SE2N-18 — A, B, C, D or E
	1/4	SE2N-25
	5/16	SE2N-31
	3/8	SE2N-37
	1/2	SE2N-50
#4-40	3/16	SE4N-18 — A, B, C, D or E
	1/4	SE4N-25
	5/16	SE4N-31
	3/8	SE4N-37
	1/2	SE4N-50
	5/8	SE4N-62
#6-32	1/4	SE6N-25 — A, B, C, D or E
	5/16	SE6N-31
	3/8	SE6N-37
	1/2	SE6N-50
	5/8	SE6N-62
	3/4	SE6N-75
#8-32	1/4	SE8N-25 — A, B, C, D or E
	5/16	SE8N-31
	3/8	SE8N-37
	1/2	SE8N-50
	5/8	SE8N-62
	3/4	SE8N-75
	1	SE8N-100
#10-24	1/4	SE01N-25 — A, B, C, D or E
	5/16	SE01N-31
	3/8	SE01N-37
	1/2	SE01N-50
	5/8	SE01N-62
	3/4	SE01N-75
	1	SE01N-100
#10-32	1/4	SE11N-25 — A, B, C, D or E
	5/16	SE11N-31
	3/8	SE11N-37
	1/2	SE11N-50
	5/8	SE11N-62
	3/4	SE11N-75
	1	SE11N-100
1/4-20	3/8	SE21N-37 — A, B, C, D or E
	1/2	SE21N-50
	5/8	SE21N-62
	3/4	SE21N-75
	1	SE21N-100

* Type D is Only Available
 with NYLOC® Insert

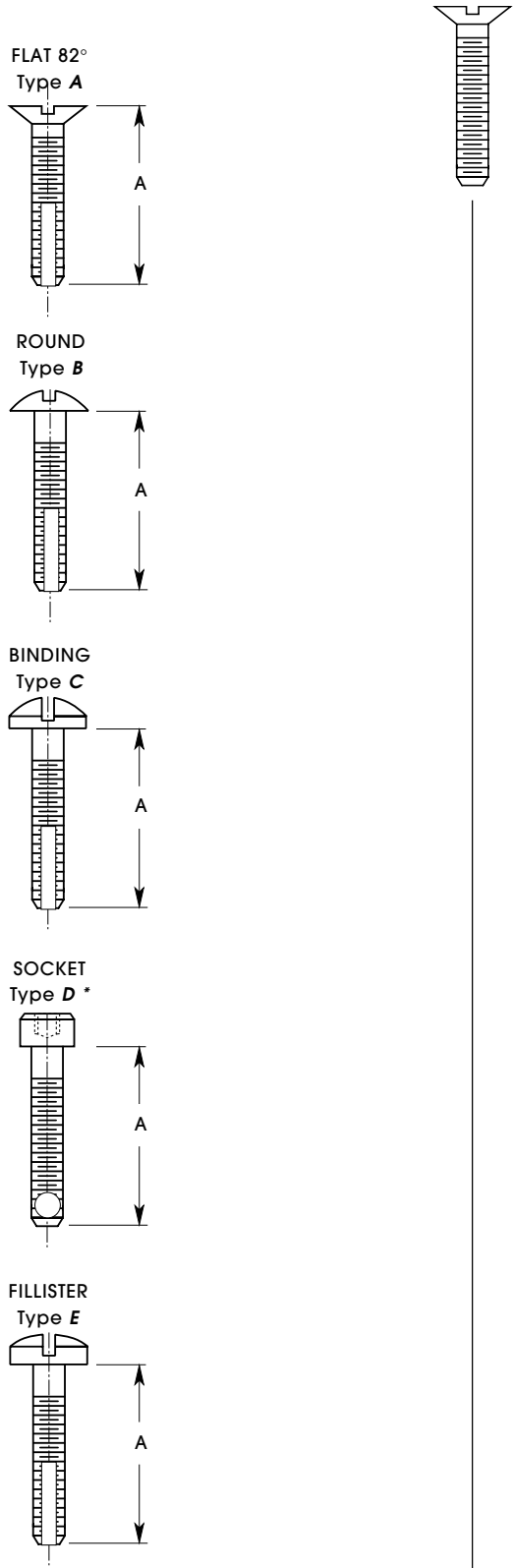

"LONG-LOK"® REG. LONG LOK CORP.
 "NYLOC"® REG. NYLOC CORP.

For Specifications Turn To Next Page

SCREW SPECIFICATIONS

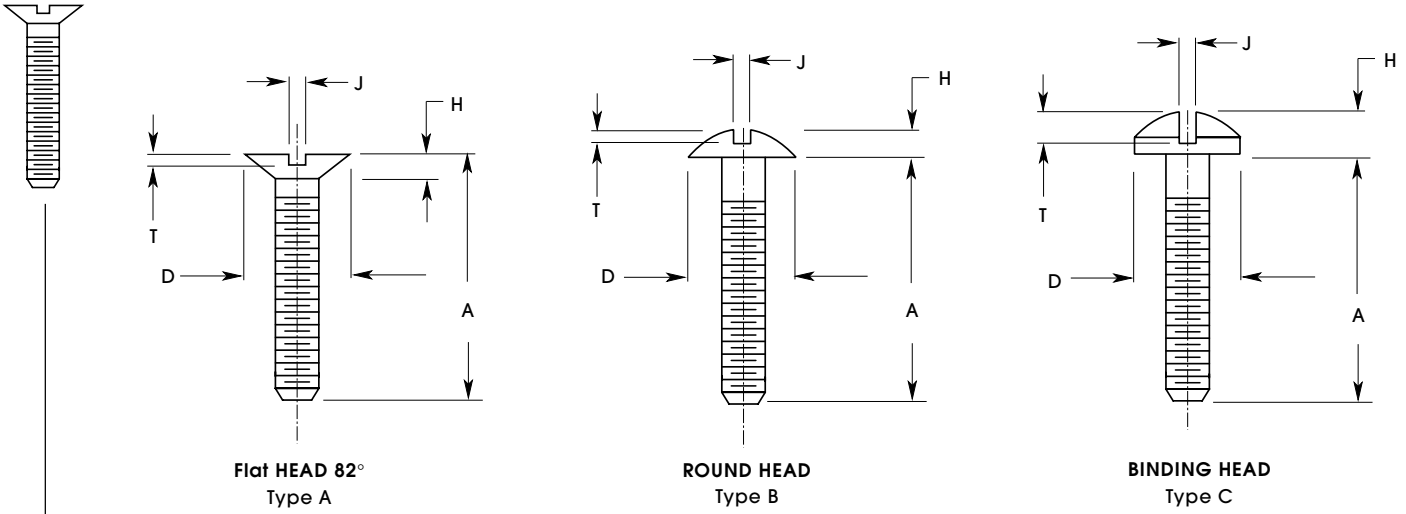

SCREW SIZE	TYPE A FLAT HEAD 82°				TYPE B ROUND HEAD				TYPE C FILLISTER HEAD			
	D MAX	H	J MAX	T MAX	D	H	J	T	D MAX	H MAX	J MAX	T MAX
#000	.064	.016	.011	.009	.062	.031	.012	.018	.059	.035	.012	.017
#00	.092	.028	.017	.014	.089	.045	.017	.026	.082	.047	.017	.022
#0	.119	.035	.023	.015	.113	.053	.023	.039	.096	.055	.023	.025
#2	.0172	.051	.031	.023	.162	.069	.031	.048	.140	.083	.031	.037
#4	.225	.067	.039	.030	.211	.086	.039	.058	.183	.107	.039	.048
#6	.279	.083	.048	.038	.260	.103	.048	.068	.226	.132	.048	.060
#8	.332	.100	.054	.045	.309	.120	.054	.077	.270	.156	.054	.071
#10	.385	.116	.060	.053	.359	.137	.060	.087	.313	.180	.060	.083
1/4	.507	.153	.075	.070	.472	.175	.075	.109	.414	.237	.075	.109

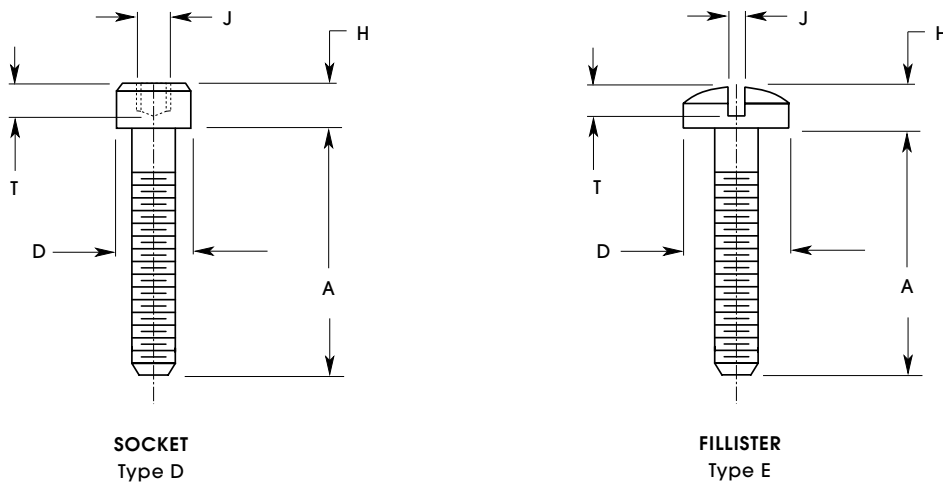

SCREW SIZE	TYPE D - CAP SOCKET HEAD				TYPE E - BINDING HEAD			
	D MAX	H MAX	J ACROSS FLATS	T MAX	D MAX	H MAX	J MAX	T MAX
#000	---	---	---	---	.073	.021	.012	.013
#00	---	---	---	---	.098	.028	.017	.018
#0	.096	.060	.050	.025	.126	.032	.023	.018
#2	.140	.086	5/64	.038	.181	.050	.031	.030
#4	.183	.112	3/32	.051	.235	.068	.039	.042
#6	.226	.138	7/64	.064	.290	.087	.048	.053
#8	.270	.164	9/64	.077	.344	.105	.054	.065
#10	.312	.190	5/32	.090	.390	.123	.060	.077
1/4"	.375	.250	3/16	.120	.525	.165	.075	.105

INTERGRAL SEAL SCREWS

300 Series Stainless Steel Screw
Silicone "O" Ring
Threads #2-56 thru 1/4-20

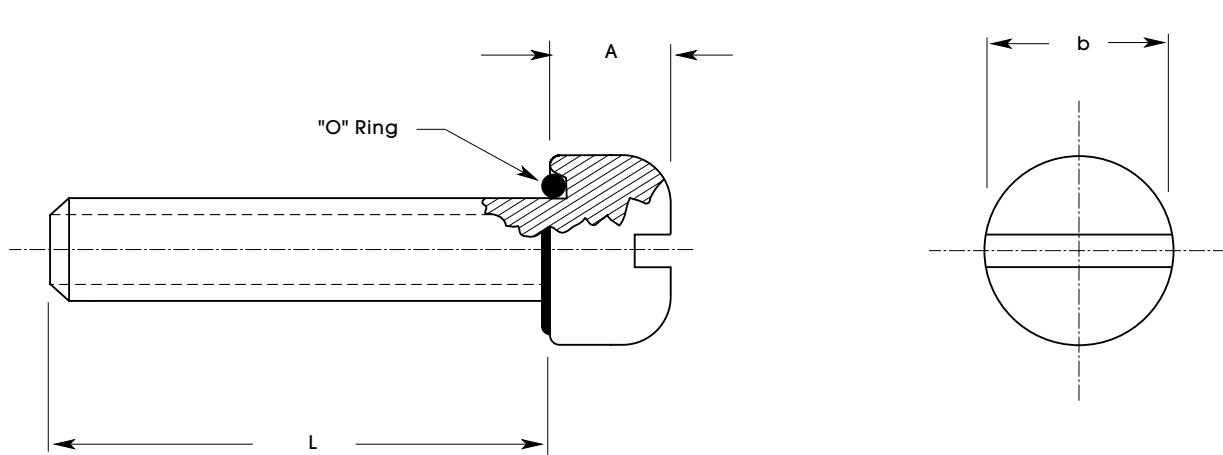

- Maximum Temperature Range +500°F To -160°F
- Pressure Range - Up to 6000PSI

THREAD SIZE	LENGTH	A	B	CLEARANCE HOLE		CATALOG NUMBER
				MIN.	MAX.	
#2-56	1/4	.055	.168	.091	.095	SE2S81Y-25
	3/8					SE2S81Y-37
	1/2					SE2S81Y-50
	5/8					SE2S81Y-62
#4-40	1/4	.069	.220	.125	.129	SE4S81Y-25
	1/2					SE4S81Y-50
	3/4					SE4S81Y-75
	1					SE4S81Y-100
#6-32	1/4	.083	.271	.147	.152	SE6S81Y-25
	1/2					SE6S81Y-50
	3/4					SE6S81Y-75
	1					SE6S81Y-100
#8-32	1/4	.097	.323	.173	.179	SE8S81Y-25
	1/2					SE8S81Y-50
	3/4					SE8S81Y-75
	1					SE8S81Y-100
#10-24	3/8	.113	.374	.199	.204	SE01S81Y-37
	1/2					SE01S81Y-50
	3/4					SE01S81Y-75
	1					SE01S81Y-100
#10-32	3/8	.113	.374	.199	.204	SE11S81Y-37
	1/2					SE11S81Y-50
	3/4					SE11S81Y-75
	1					SE11S81Y-100
1/4-20	3/8	.148	.493	.265	.269	SE21S81Y-37
	1/2					SE21S81Y-50
	3/4					SE21S81Y-75
	1					SE21S81Y-100
	1-1/4					SE21S81Y-125

SET SCREWS *CUP POINT*

Stainless Type 18-8
 Threads #0-80 thru 1/4-20
 Lengths 1/8" thru 1"

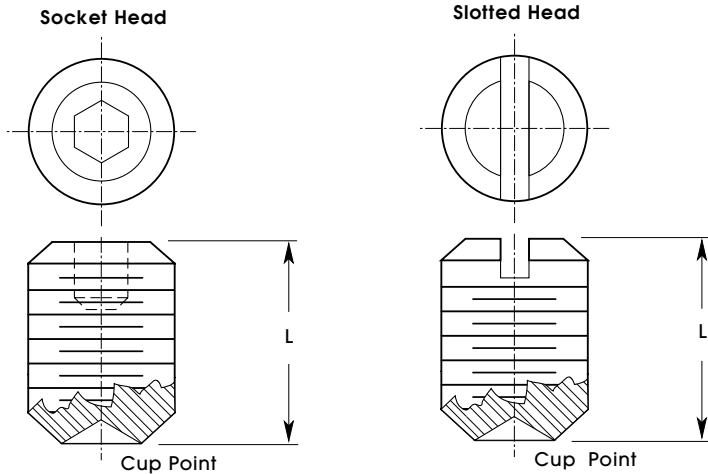
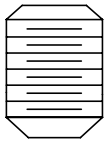

THREAD	L	CATALOG NUMBER	
		SOCKET HEAD	SLOTTED HEAD
#0-80	1/8	SE2CS-81	SE1CS-81
#0-80	3/16	SE2CS-91	SE1CS-91
#2-56	3/32	SE2CS-05	SE1CS-05
#2-56	1/8	SE2CS-1	SE1CS-1
#2-56	3/16	SE2CS-42	SE1CS-42
#2-56	1/4	SE2CS-52	----
#4-40	3/32	SE2CS-15	SE1CS-15
#4-40	1/8	SE2CS-2	SE1CS-2
#4-40	3/16	SE2CS-72	----
#4-40	1/4	SE2CS-82	----
#6-32	3/32	SE2CS-25	----
#6-32	1/8	SE2CS-3	SE1CS-3
#6-32	1/4	SE2CS-03	----
#6-32	3/8	SE2CS-13	----
#8-32	1/8	SE2CS-35	----
#8-32	3/16	SE2CS-4	SE1CS-4
#8-32	1/4	SE2CS-33	----
#8-32	3/8	SE2CS-43	----
#8-32	1/2	SE2CS-53	----
#10-24	3/16	SE2CS-61	----
#10-24	1/4	SE2CS-26	----
#10-32	3/16	SE2CS-5	SE1CS-5
#10-32	1/4	SE2CS-73	----
#10-32	3/8	SE2CS-55	----
#10-32	1/2	SE2CS-83	----
#10-32	3/4	SE2CS-93	----
#10-32	1	SE2CS-04	----
1/4-20	1/4	SE2CS-14	----
1/4-20	5/16	SE2CS-65	----
1/4-20	3/8	SE2CS-6	SE1CS-6
1/4-20	1/2	SE2CS-24	----

SET SCREWS *BRASS TIP*

303 Stainless Steel • Alloy Steel
 Threads #2-56 thru 3/8-16
 Lengths 1/8" thru 3/4"

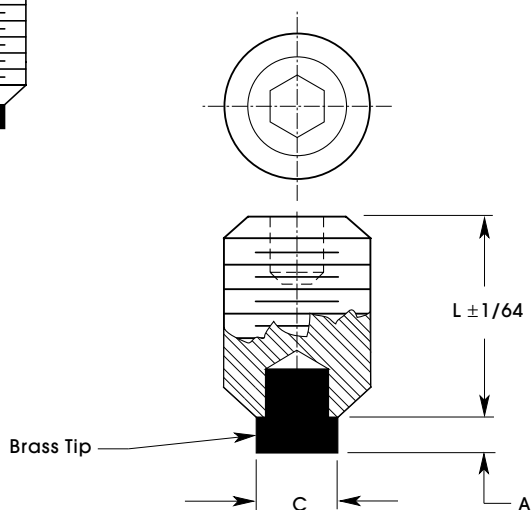

THREAD	L	C	A	MATERIAL	CATALOG NUMBER
#2-56	1/8	1/32	1/32	303 STAINLESS STEEL	SE01CS-03
	1/4				SE01CS-13
#4-40	1/8	1/16	1/32		SE01CS-23
	1/4				SE01CS-33
	3/8				SE01CS-43
#6-32	1/8	1/16	1/32		SE01CS-53
	1/4			SE01CS-63	
	3/8			SE01CS-73	
#8-32	3/16	3/32	3/64	ALLOY STEEL BLACK OXIDE FINISH ROCKWELL C48-52	SE01CS-83
	1/4				SE01CS-93
	3/8				SE01CS-04
#10-32	1/4	1/8	3/64		SE01CS-1
	3/8				SE01CS-2
	1/2				SE01CS-3
1/4-20	3/16	1/8	3/64		SE01CS-4
	1/4				SE01CS-5
	5/16				SE01CS-6
	3/8				SE01CS-7
	1/2				SE01CS-8
	3/4				SE01CS-01
5/16-18	3/8	3/16	3/64	SE01CS-41	
	1/2			SE01CS-51	
	5/8			SE01CS-61	
3/8-16	3/8	3/16	3/64	SE01CS-12	
	1/2			SE01CS-22	
	3/4			SE01CS-42	

"SOFT" TIP SET SCREW

Stainless Type 18-8
Threads #2-56 thru 3/8-16
Lengths 5/32" thru 1-1/16"

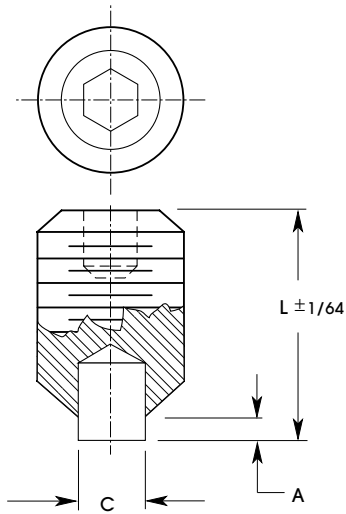

Socket Head

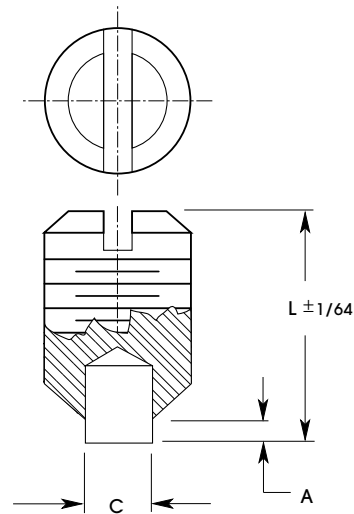

Slotted Head

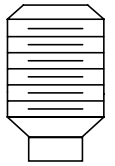

THREAD	L	C	A	CATALOG NUMBER	
				SOCKET HEAD	SLOTTED HEAD
#2-56	5/32	1/32	1/32	SE8CS-1	SE8CS-1-SL
	1/4			SE8CS-2	SE8CS-2-SL
	9/32			SE8CS-13	SE8CS-13-SL
#4-40	5/32	1/16	1/32	SE8CS-5	SE8CS-5-SL
	9/32			SE8CS-23	SE8CS-23-SL
	3/8			SE8CS-6	SE8CS-6-SL
	13/32			SE8CS-33	SE8CS-33-SL
#5-40	5/32	1/16	1/32	SE8CS-7	SE8CS-7-SL
	3/8			SE8CS-8	SE8CS-8-SL
#6-32	5/32	1/16	1/32	SE8CS-17	SE8CS-17-SL
	7/32			SE8CS-9	SE8CS-9-SL
	9/32			SE8CS-92	SE8CS-92-SL
	5/16			SE8CS-01	SE8CS-01-SL
	17/32			SE8CS-43	SE8CS-43-SL
#8-32	15/64	3/32	3/64	SE8CS-11	SE8CS-11-SL
	3/8			SE8CS-21	SE8CS-21-SL
	17/64			SE8CS-81	SE8CS-81-SL
	27/64			SE8CS-03	SE8CS-03-SL
	43/64			SE8CS-35	SE8CS-35-SL
#10-24	15/64	3/32	3/64	SE8CS-91	SE8CS-91-SL
	27/64			SE8CS-02	SE8CS-02-SL
#10-32	15/64	3/32	3/64	SE8CS-31	SE8CS-31-SL
	5/16			SE8CS-41	SE8CS-41-SL
	27/64			SE8CS-12	SE8CS-12-SL
	43/64			SE8CS-63	SE8CS-63-SL
1/4-20	15/16	1/8	1/16	SE8CS-51	SE8CS-51-SL
	7/16			SE8CS-22	SE8CS-22-SL
	1/2			SE8CS-61	SE8CS-61-SL
	13/16			SE8CS-73	SE8CS-73-SL
	1-1/16			SE8CS-83	SE8CS-83-SL
1/4-28	7/16	1/8	1/16	SE8CS-32	SE8CS-32-SL
5/16-18	19/32	3/16	3/32	SE8CS-42	SE8CS-42-SL
3/8-16	19/32	3/16	3/32	SE8CS-52	SE8CS-52-SL

THUMB SCREW

416 Stainless Steel • 303 Stainless Steel — RC 26-32

Threads #4-40 thru 1/4-20

Lengths 1/2" thru 2-3/16"

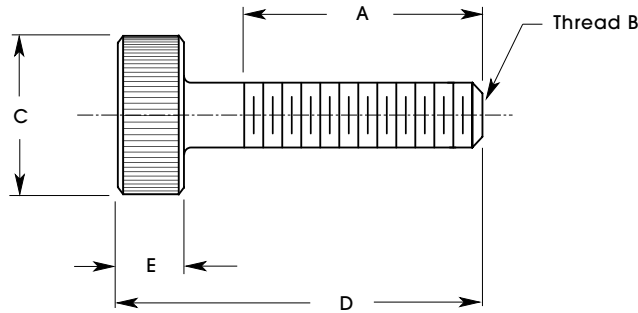
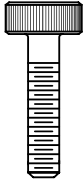

THREAD B	C	D	A	E	CATALOG NUMBER	
					416 STEEL	303 STEEL
#4-40	1/4	1/2	5/16	1/2	SE1QP-1	SE2QP-1
		1	7/16	1/2	SE1QP-2	SE2QP-2
		1-1/4	5/8	1/8	SE1QP-3	SE2QP-3
#4-40	3/8	1-1/2	5/16	1/8	SE1QP-4	SE2QP-4
		1/2	5/16		SE1QP-5	SE2QP-5
		5/8	7/16		SE1QP-6	SE2QP-6
#6-32	1/4	1	7/16	1/2	SE1QP-7	SE2QP-7
		1-1/4	5/8		SE1QP-8	SE2QP-8
		1-1/2	13/16		SE1QP-9	SE2QP-9
#6-32	3/8	1/2	5/16	1/8	SE1QP-10	SE2QP-10
		5/8	3/8		SE1QP-11	SE2QP-11
#8-32	1/4	1	7/16	1/2	SE1QP-12	SE2QP-12
		1-1/4	5/8		SE1QP-13	SE2QP-13
		1-1/2	13/16		SE1QP-14	SE2QP-14
#8-32	3/8	1/2	5/16	1/8	SE1QP-15	SE2QP-15
		5/8	3/8		SE1QP-16	SE2QP-16
#10-24	3/8	11/16	7/16	3/16	SE1QP-17	SE2QP-17
		15/16	5/8		SE1QP-18	SE2QP-18
		1-3/16	13/16		SE1QP-19	SE2QP-19
		1-7/16	1		SE1QP-20	SE2QP-20
#10-24	1/2	15/16	5/8	3/16	SE1QP-21	SE2QP-21
		1-3/16	13/16		SE1QP-22	SE2QP-22
		1-7/16	1		SE1QP-23	SE2QP-23
		1-11/16	1-1/4		SE1QP-24	SE2QP-24
#10-24	3/4	15/16	5/8	3/16	SE1QP-25	SE2QP-25
		1-3/16	13/16		SE1QP-26	SE2QP-26
		1-7/16	1		SE1QP-27	SE2QP-27
		1-11/16	1-1/4		SE1QP-28	SE2QP-28
#10-24	3/8	11/16	7/16	3/16	SE1QP-29	SE2QP-29
		15/16	5/8		SE1QP-30	SE2QP-30
		1-3/16	13/16		SE1QP-31	SE2QP-31
		1-7/16	1		SE1QP-32	SE2QP-32
#10-32	1/2	15/16	5/8	3/16	SE1QP-33	SE2QP-33
		1-3/16	13/16		SE1QP-34	SE2QP-34
		1-7/16	1		SE1QP-35	SE2QP-35
		1-11/16	1-1/4		SE1QP-36	SE2QP-36
#10-24	3/4	15/16	5/8	3/16	SE1QP-37	SE2QP-37
		1-3/16	13/16		SE1QP-38	SE2QP-38
		1-7/16	1		SE1QP-39	SE2QP-39
		1-11/16	1-1/4		SE1QP-40	SE2QP-40
1/4-20	3/4	15/16	5/8	3/16	SE1QP-41	SE2QP-41
		1-3/16	13/16		SE1QP-42	SE2QP-42
		1-7/16	1		SE1QP-43	SE2QP-43
		1-11/16	1-1/4		SE1QP-44	SE2QP-44
		2-3/16	1-5/8		SE1QP-45	SE2QP-45
1/4-20	1	15/16	5/8	3/16	SE1QP-46	SE2QP-46
		1-3/16	13/16		SE1QP-47	SE2QP-47
		1-7/16	1		SE1QP-48	SE2QP-48
		1-11/16	1-1/4		SE1QP-49	SE2QP-49
		2-3/16	1-5/8		SE1QP-50	SE2QP-50

PLASTIC HEAD THUMB SCREW

Stainless Type 18-8
Threads #4-40 thru 1/4-20
Lengths 1/4" thru 1"

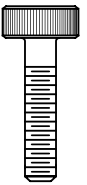
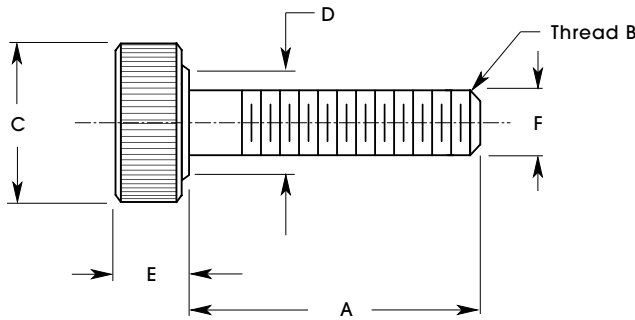

THREAD B	C	D	E	F	F	CATALOG NUMBER
#4-40	5/16	11/64	9/32	.112	1/4	SECQP-1
					5/16	SECQP-2
					3/8	SECQP-3
					1/2	SECQP-4
					5/8	SECQP-5
#6-32	3/8	3/16	21/64	.138	15/16	SECQP-6
					3/8	SECQP-7
					1/2	SECQP-8
					5/8	SECQP-9
					3/4	SECQP-10
#8-32	1/2	7/32	3/8	.164	3/8	SECQP-11
					1/2	SECQP-12
					5/8	SECQP-13
					3/4	SECQP-14
					1	SECQP-15
#10-32	5/8	1/4	27/64	.190	3/8	SECQP-21
					1/2	SECQP-22
					5/8	SECQP-23
					3/4	SECQP-24
					1	SECQP-25
1/4-20	3/4	5/16	1/2	.250	3/8	SECQP-26
					1/2	SECQP-27
					5/8	SECQP-28
					3/4	SECQP-29
					1	SECQP-30
1/4-20	1	5/16	1/2	.250	3/8	SECQP-31
					1/2	SECQP-32
					5/8	SECQP-33
					3/4	SECQP-34
					1	SECQP-35

BRASS THUMB SCREW

Brass
Threads #6-32 • #8-32
Lengths 1/4" thru 1"

A	THREAD B	C	D	CATALOG NUMBER/FINISH	
				NICKEL PLATE	BLACK OXIDE
13/16	#6-32	3/8	23/32	EH24-1	EH24-2
1/2	#6-32	3/8	13/16	EH24-3	EH24-4
13/32	#6-32	7/16	23/32	EH24-5	EH24-6
1/2	#6-32	7/16	13/16	EH24-7	EH24-8
13/32	#6-32	1/2	23/32	EH24-9	EH24-10
1/2	#6-32	1/2	13/16	EH24-11	EH24-12
13/32	#8-32	3/8	23/32	EH24-13	EH24-14
1/2	#8-32	3/8	13/16	EH24-15	EH24-16
13/32	#8-32	7/16	23/32	EH24-17	EH24-18
1/2	#8-32	7/16	13/16	EH24-19	EH24-20
13/32	#8-32	1/2	23/32	EH24-21	EH24-22

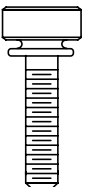
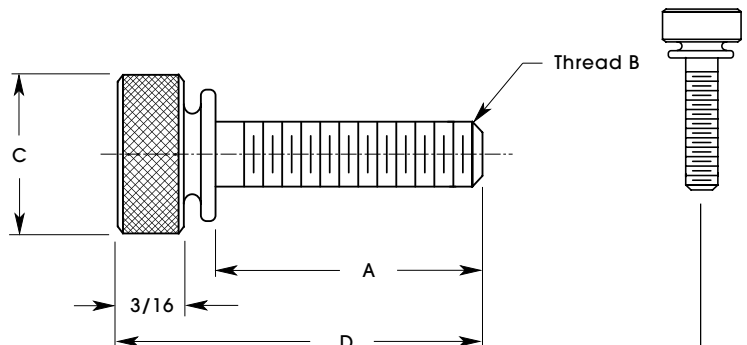

PUSHER SCREW

303 Stainless Steel

Threads #4-40 thru #10-32

Lengths 1/2" thru 1-1/4"

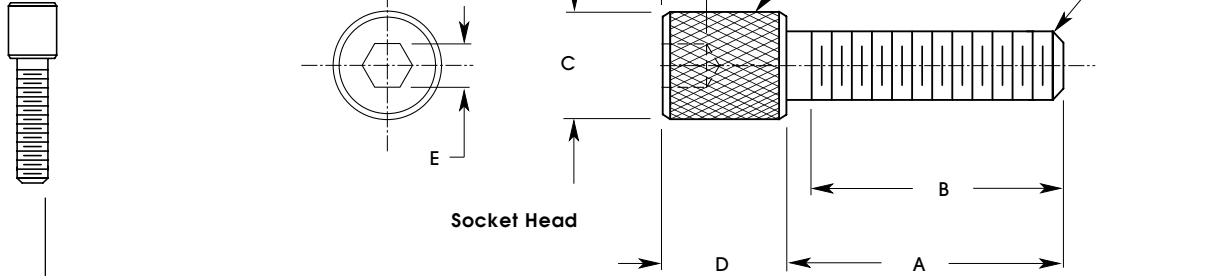

THREAD	A	C	D	B	E	F	CATALOG NUMBER
#4-40	1/2	1/4	1/2	7/16	5/64	1/16	SH55-1
	3/4			5/8			SH55-2
#4-40	1/2	5/16	1/2	7/16	3/32	5/64	SH55-3
	3/4			5/8			SH55-4
#4-40	3/8	3/8	1/2	5/16	1/8	3/32	SH55-5
	1/2			7/16			SH55-6
#6-32	1/2	1/4	1/2	7/16	5/64	1/16	SH55-7
	3/4			5/8			SH55-8
	1			13/16			SH55-9
#6-32	1/2	5/16	1/2	7/16	3/32	5/64	SH55-10
	3/4			5/8			SH55-11
	1			13/16			SH55-12
#6-32	3/8	3/8	1/2	5/16	1/8	3/32	SH55-13
	1/2			3/8			SH55-14
#8-32	1/2	1/4	1/2	7/16	5/64	1/16	SH55-15
	3/4			5/8			SH55-16
	1			13/16			SH55-17
#8-32	1/2	5/16	1/2	7/16	3/32	5/64	SH55-18
	3/4			5/8			SH55-19
	1			13/16			SH55-20
#8-32	3/8	3/8	1/2	5/16	1/8	3/32	SH55-21
	1/2			3/8			SH55-22
#10-24	1/2	5/16	3/16	7/16	3/32	5/64	SH55-23
	3/4			5/8			SH55-24
	1			13/16			SH55-25
	1-1/4			1			SH55-26
#10-24	1/2	3/8	1/2	7/16	1/8	3/32	SH55-27
	3/4			5/8			SH55-28
	1			13/16			SH55-29
	1-1/4			1			SH55-30
#10-32	1/2	5/16	3/16	7/16	3/32	5/64	SH55-31
	3/4			5/8			SH55-32
	1			13/16			SH55-33
	1-1/4			1			SH55-34
#10-32	1/2	3/8	1/2	7/16	1/8	3/32	SH55-35
	3/4			5/8			SH55-36
	1			13/16			SH55-37
	1-1/4			1			SH55-38

Brass Plated

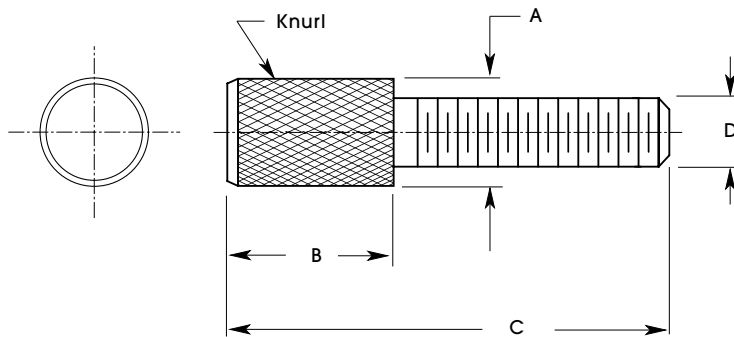

A	B	C	THREAD D	CATALOG NUMBER
3/16	3/8	1-1/8	#6-32	SH5-1
		1-3/8		SH5-2
		1-5/8		SH5-3
		1-7/8		SH5-4
3/16	3/8	1-1/8	#8-32	SH5-5
		1-3/8		SH5-6
		1-5/8		SH5-7
		1-7/8		SH5-8
1/4	1/2	1-1/2	#10-24	SH5-9
		1-3/4		SH5-10
		2		SH5-11
		2-1/4		SH5-12
5/16	1/2	1-3/4	1/4-20	SH5-13
		2		SH5-14
		2-1/4		SH5-15
		2-1/4		SH5-16

PRECISION SHOULDER SCREW

303 Stainless Steel • 416 Stainless Steel

Threads #4-40 thru #10-32

Lengths 5/32" thru 5/8"

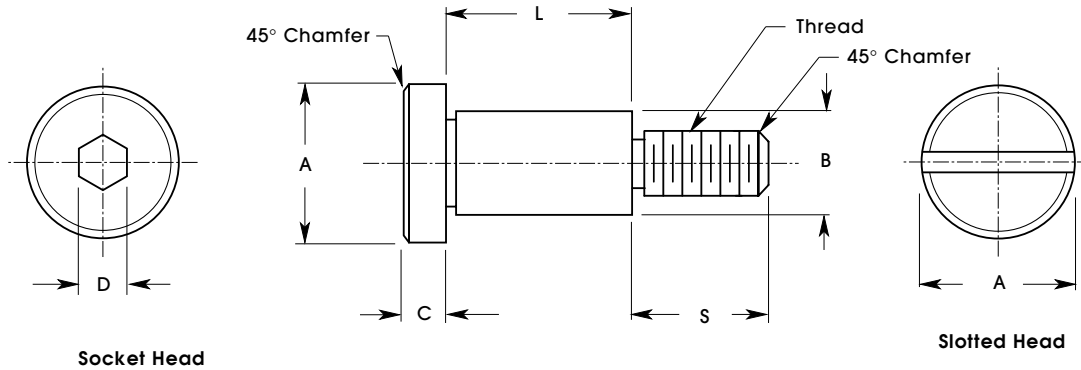

Socket Head

Slotted Head

Add 416 After Catalog Number for 416 Stainless Steel
Example: "SH6-1-416"

A	+ .001 - .000 DIAMETER	C	D	THREAD	+ .002 - .000 L	S	CATALOG NUMBER/HEAD	
							SLOTTED HEAD	SOCKET HEAD
1/4	.1245	1/8	5/64	#4-40		5/32	SH6-1	SH6-28
							SH6-2	SH6-29
							SH6-3	SH6-30
							SH6-4	SH6-31
							SH6-5	SH6-32
5/16	.1870	5/32	3/32	#8-32		3/16	SH6-6	SH6-33
							SH6-7	SH6-34
							SH6-8	SH6-35
							SH6-9	SH6-36
							SH6-10	SH6-37
							SH6-11	SH6-38
							SH6-12	SH6-39
							SH6-13	SH6-40
							SH6-14	SH6-41
							SH6-15	SH6-42
							SH6-16	SH6-43
3/8	.2495	3/16	1/8	#10-32		1/4	SH6-17	SH6-44
							SH6-18	SH6-45
							SH6-19	SH6-46
							SH6-20	SH6-47
							SH6-21	SH6-48
							SH6-22	SH6-49
							SH6-23	SH6-50
							SH6-24	SH6-51
							SH6-25	SH6-52
							SH6-26	SH6-53
							SH6-27	SH6-54
1/2	.3120	7/32	5/32	1/4-20		7/16	SH6-55	SH6-73
							SH6-56	SH6-74
							SH6-57	SH6-75
							SH6-58	SH6-76
							SH6-59	SH6-77
1/2	.3750	7/32	5/32	1/4-20		7/16	SH6-60	SH6-78
							SH6-61	SH6-79
							SH6-62	SH6-80
							SH6-63	SH6-81
9/16	.3745	1/4	3/16	5/16-18		1/2	SH6-64	SH6-82
							SH6-65	SH6-83
							SH6-66	SH6-84
							SH6-67	SH6-85
3/4	.4995	5/16	1/4	3/8-16		5/8	SH6-68	SH6-86
							SH6-69	SH6-87
							SH6-70	SH6-88
							SH6-71	SH6-89
							SH6-72	SH6-90

CAPTIVE THUMB SCREW

303 Stainless Steel • Brass
 Threads #6-32 thru 1/4-20
 Lengths 3/4" thru 1-1/8"

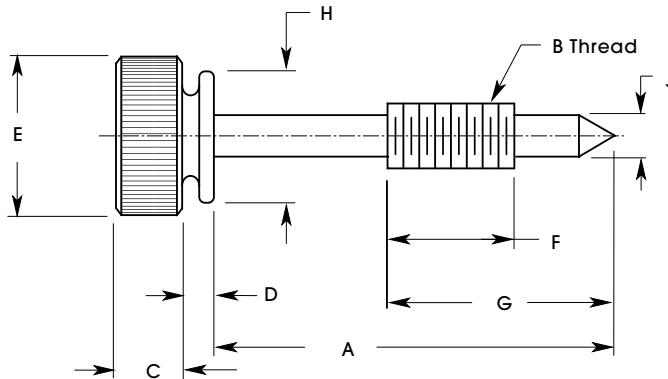
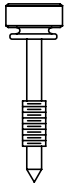

Material:
 Stainless Steel
Finish — Clear Passivate

A	B	C	D	E	F	G	H	J	CATALOG NUMBER
3/4	#6-32	1/8	1/16	5/16	3/16	5/16	.20	.09	EH23-1
3/4	#8-32							.12	EH23-2
7/8	#8-32							.12	EH23-3
7/8	#10-32	3/16	1/16	5/8	1/4	3/8	1/2	.12	EH23-4
1	#10-32							.12	EH23-5
7/8	#12-24							.18	EH23-6
7/8	1/4-20							.18	EH23-7
1	1/4-20							.18	EH23-8
1	1/4-20	1/4	1/8	3/4	3/8	5/8	1/2	.18	EH23-9
1-1/8	1/4-20							.18	EH23-10

Material:
 Brass
Finish — Nickel Plate or Black Oxide

A	B	C	D	E	F	G	H	J	CATALOG NUMBER/FINISH	
									NICKEL PLATE	BLACK OXIDE
3/4	#6-32	1/8	1/16	5/16	3/16	5/16	.20	.09	EH23-11	EH23-12
3/4	#8-32								EH23-13	EH23-14
7/8	#8-32	3/16	1/16	5/8	1/4	3/8	1/2	.12	EH23-15	EH23-16
7/8	#10-32								EH23-17	EH23-18
1	#10-32								EH23-19	EH23-20
7/8	#12-24	3/16	1/16	5/8	1/4	3/8	1/2	.18	EH23-21	EH23-22
7/8	1/4-20								EH23-23	EH23-24
1	1/4-20								EH23-25	EH23-26
1	1/4-20	1/4	1/8	3/4	3/8	5/8	1/2	.18	EH23-27	EH23-28
1-1/8	1/4-20								EH23-29	EH23-30

CAPTIVE SCREW

303 Stainless Steel
Threads #4-40 thru #10-32
Lengths .187 thru .312

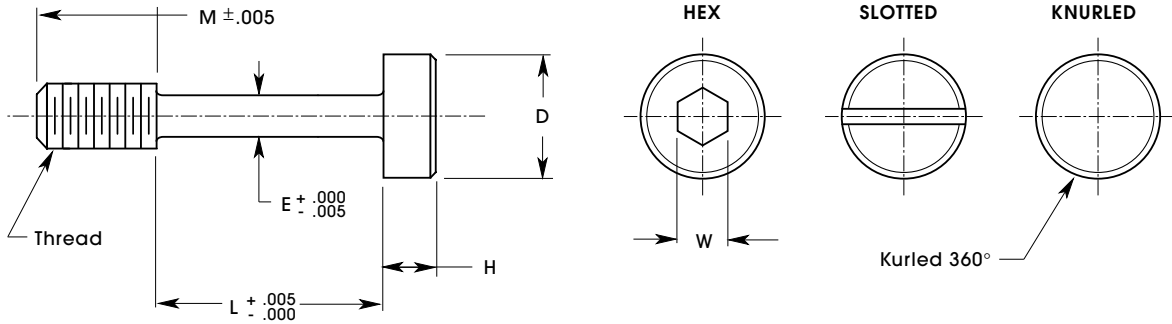

L	M	H	E	D	THREAD UN-2A	W	CATALOG NUMBER/HEAD TYPE		
							SLOTTED	HEX	KNURLED
.281	.187	1/8	.072	1/4	#4-40	5/64	SE21Z-1	SE21ZH-1	SE21ZK-1
.343	.187	1/8	.072	1/4	#4-40	5/64	SE21Z-2	SE21ZH-2	SE21ZK-2
.312	.218	1/8	.086	9/32	#6-32	5/64	SE21Z-3	SE21ZH-3	SE21ZK-3
.375	.218	1/8	.086	9/32	#6-32	5/64	SE21Z-4	SE21ZH-4	SE21ZK-4
.437	.218	1/8	.086	9/32	#6-32	5/64	SE21Z-5	SE21ZH-5	SE21ZK-5
.406	.250	5/32	.114	5/16	#8-32	3/32	SE21Z-6	SE21ZH-6	SE21ZK-6
.468	.250	5/32	.114	5/16	#8-32	3/32	SE21Z-7	SE21ZH-7	SE21ZK-7
.531	.250	5/32	.114	5/16	#8-32	3/32	SE21Z-8	SE21ZH-8	SE21ZK-8
.531	.312	3/16	.136	3/8	#10-32	1/8	SE21Z-9	SE21ZH-9	SE21ZK-9
.593	.312	3/16	.136	3/8	#10-32	1/8	SE21Z-10	SE21ZH-10	SE21ZK-10

KNURLED THUMB NUT

303 Stainless Steel
Threads #4-40 thru 1/4-20
Diameters 1/2" thru 1"

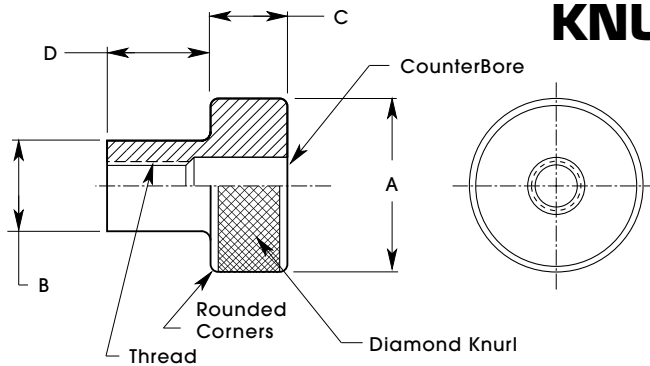

THREAD	A	B	C	D	COUNTERBORE		CATALOG NUMBER
					DIAMETER	DEPTH	
#4-40	1/2	1/4	1/8	1/4	1/8	1/8	SE1DP-1
	1/2			1/8	3/8	SE1DP-2	
	3/4			1/8	1/8	SE1DP-3	
	3/4			1/8	3/8	SE1DP-4	
#6-32	1/2	1/4	1/8	1/4	#26	3/32	SE1DP-5
	1/2			#26	11/32	SE1DP-6	
	3/4			#26	3/32	SE1DP-7	
	3/4			#26	11/32	SE1DP-8	
#8-32	1/2	5/16	1/8	1/4	---	---	SE1DP-9
	1/2			#15	1/4	SE1DP-10	
	3/4			---	---	SE1DP-11	
	3/4			#15	1/4	SE1DP-12	
#10-24	1/2	3/8	3/16	1/4	---	---	SE1DP-13
	1/2			13/64	1/4	SE1DP-14	
	1			---	---	SE1DP-15	
	1			13/64	1/4	SE1DP-16	
#10-32	1/2	3/8	3/16	1/4	---	---	SE1DP-17
	1/2			13/64	1/4	SE1DP-18	
	1			---	---	SE1DP-19	
	1			13/64	1/4	SE1DP-20	
1/4-20	3/4	1/2	1/4	1/4	---	---	SE1DP-21
	3/4			17/64	1/4	SE1DP-22	
	1			---	---	SE1DP-23	
	1			17/64	1/4	SE1DP-24	
	1			3/4	17/64	1/2	SE1DP-25

CHASSIS HANDLES *FOLDABLE ROUND*

Material: Brass

Finish — Polished Nickel Plate or Black Oxide

Stainless Steel Available by Request

Nuts and Washers Supplied

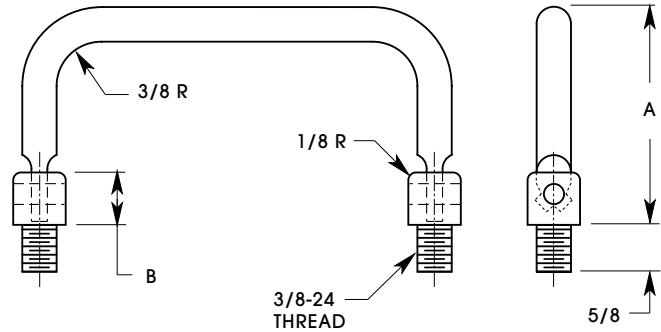
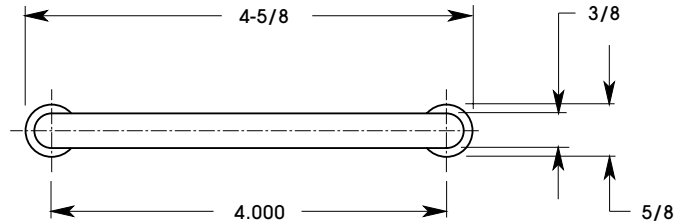
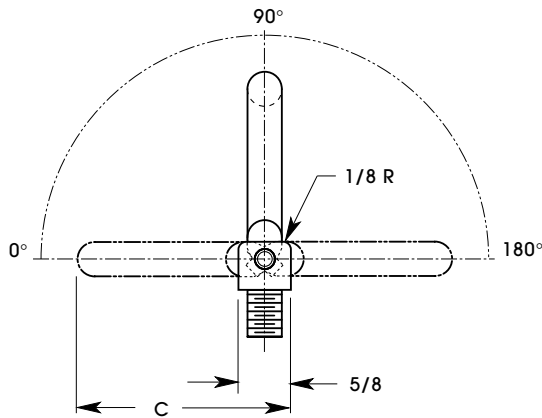

ROTATION	A	B	C	CATALOG NUMBER/MATERIAL	
				POLISHED NICKEL PLATE	BLACK OXIDE
90°	1-27/32	1/2	1-27/32	EH8-31	EH8-32
180°	1-13/16	5/8	1-13/16	EH8-37	EH8-38

CHASSIS HANDLES *OVAL*

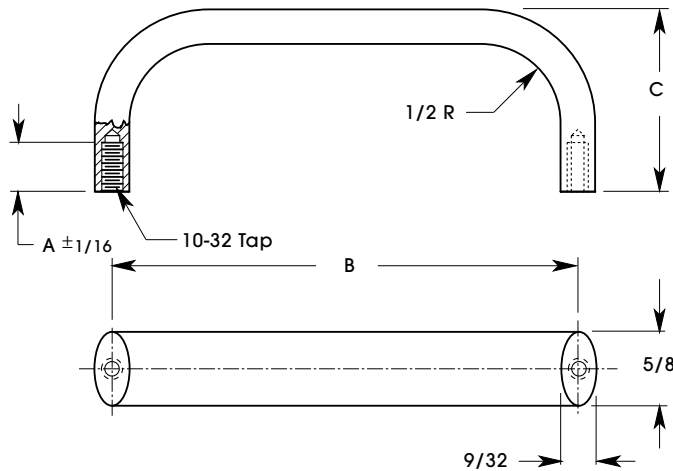

A	B	C	MATERIAL	FINISH	CATALOG NUMBER
1/2	3	1-9/32	BRASS	POLISHED NICKEL	EH8-41
1/2	3	1-9/32	BRASS	BLACK OXIDE	EH8-42
9/32	3	1-9/32	AL	BLACK ALUMILITE	EH8-43
1/2	4-9/16	1-1/2	BRASS	POLISHED NICKEL	EH8-44
1/2	4-9/16	1-1/2	BRASS	BLACK OXIDE	EH8-45
1/2	4-9/16	1-1/2	AL	BLACK ALUMILITE	EH8-46
1/2	6-7/16	1-3/4	BRASS	POLISHED NICKEL	EH8-47
1/2	6-7/16	1-3/4	BRASS	BLACK OXIDE	EH8-48
9/32	6-1/16	1-3/4	AL	BLACK ALUMILITE	EH8-49
9/32	9	1-3/4	BRASS	POLISHED NICKEL	EH8-50
1/2	9	1-3/4	BRASS	BLACK OXIDE	EH8-51
9/32	9	1-3/4	AL	BLACK ALUMILITE	EH8-52

CHASSIS HANDLE

Internal Thread
Brass • SS • Al

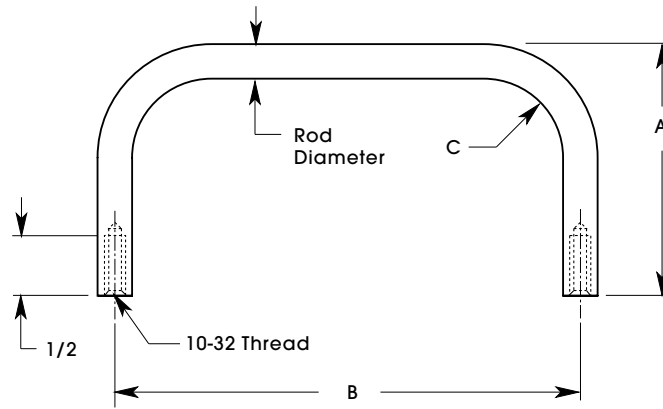

SECS can Supply Handles in Accord with MS 39087

ROD DIAMETER	A	B	C	FERRULE STYLE	MATERIAL	FINISH	CATALOG NUMBER
5/16	1-5/16	3	5/16	1	BRASS	NICKEL PLATE	EH8-1
5/16	1-5/16	3	5/16	1	SS	PLAIN	EH8-2
5/16	1-5/16	3	5/16	1	AL	BLACK ANODIZE	EH8-3
5/16	1-1/2	3	5/16	1	BRASS	NICKEL PLATE	EH8-4
5/16	1-1/2	3	5/16	1	SS	PLAIN	EH8-5
5/16	1-1/2	3	5/16	1	AL	BLACK ANODIZE	EH8-6
3/8	1-7/8	4	1/2	2	BRASS	NICKEL PLATE	EH8-7
3/8	1-7/8	4	1/2	2	AL	BLACK ANODIZE	EH8-8
5/16	1-1/2	4-1/4	5/16	1	BRASS	NICKEL PLATE	EH8-9
5/16	1-1/2	4-1/4	5/16	1	SS	PLAIN	EH8-10
5/16	1-1/2	4-1/4	5/16	1	AL	BLACK ANODIZE	EH8-11
5/16	1-1/2	4-1/2	5/16	1	BRASS	NICKEL PLATE	EH8-12
5/16	1-1/2	4-1/2	5/16	1	SS	PLAIN	EH8-13
5/16	1-1/2	4-1/2	5/16	1	AL	BLACK ANODIZE	EH8-14
3/8	1-1/2	4-1/2	1/2	2	BRASS	NICKEL PLATE	EH8-15
3/8	1-1/2	4-1/2	1/2	2	AL	BLACK ANODIZE	EH8-16
5/16	1-1/2	4-9/16	5/16	1	BRASS	NICKEL PLATE	EH8-17
5/16	1-1/2	4-9/16	5/16	1	SS	PLAIN	EH8-18
5/16	1-1/2	4-9/16	5/16	1	AL	BLACK ANODIZE	EH8-19
5/16	1-1/2	6	5/16	1	BRASS	NICKEL PLATE	EH8-20
5/16	1-1/2	6	5/16	1	SS	PLAIN	EH8-21
5/16	1-1/2	6	5/16	1	AL	BLACK ANODIZE	EH8-22
5/16	1-3/4	6-7/16	5/16	1	BRASS	NICKEL PLATE	EH8-23
5/16	1-3/4	6-7/16	5/16	1	SS	PLAIN	EH8-24
5/16	1-3/4	6-7/16	5/16	1	AL	BLACK ANODIZE	EH8-25
5/16	1-3/4	6-1/2	5/16	1	BRASS	NICKEL PLATE	EH8-26
5/16	1-3/4	6-1/2	5/16	1	SS	PLAIN	EH8-27
5/16	1-3/4	6-1/2	5/16	1	AL	BLACK ANODIZE	EH8-28
3/8	1-3/4	6-1/2	1/2	2	BRASS	NICKEL PLATE	EH8-29
3/8	1-3/4	6-1/2	1/2	2	AL	BLACK ANODIZE	EH8-30

Ferrules

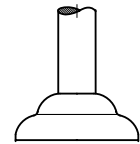

Type 1

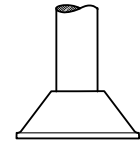

Type 2

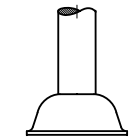

Type 3

CHASSIS HANDLE

External Thread
Brass • Al

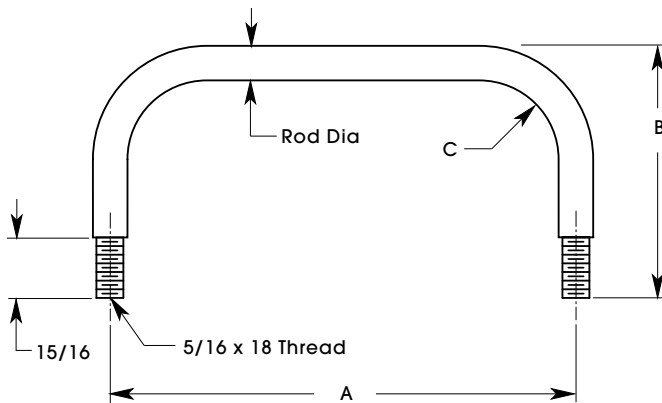

SECS can Supply Handles in Accord with MS 39087

ROD DIAMETER	A	B	C	FERRULE TYPE	CATALOG NUMBER/MATL-FIN	
					BRASS NICKEL PLATE	ALUMINUM BLACK ANODIZE
5/16	4-1/4	2-1/8	5/16	3	EH8-33	EH8-34
5/16	6	2-1/8	5/16	3	EH8-35	EH8-36

STANDARD FERRULES

Brass • Stainless Steel • Aluminum

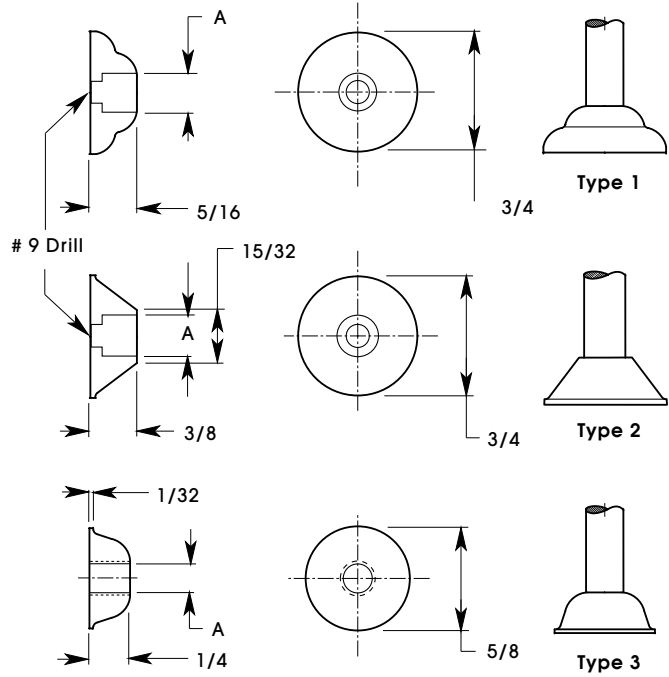
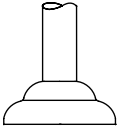

TYPE	A	MATERIAL	FINISH	CATALOG NUMBER
1	5/16	BRASS	NICKEL PLATE	EH9-1
1	5/16	SS	PLAIN	EH9-2
1	5/16	AL	BLACK ANODIZE	EH9-3
2	3/8	BRASS	NICKEL PLATE	EH9-4
2	3/8	AL	BLACK ANODIZE	EH9-5
3	5/16 x 18	BRASS	NICKEL PLATE	EH9-6
3	5/16 x 18	AL	BLACK ANODIZE	EH9-10

Special O.D. Sizes Available on Request

THREADED STUDS

303 Stainless Steel

Threads #6-32 thru 5/16-18

Length 1" thru 4"

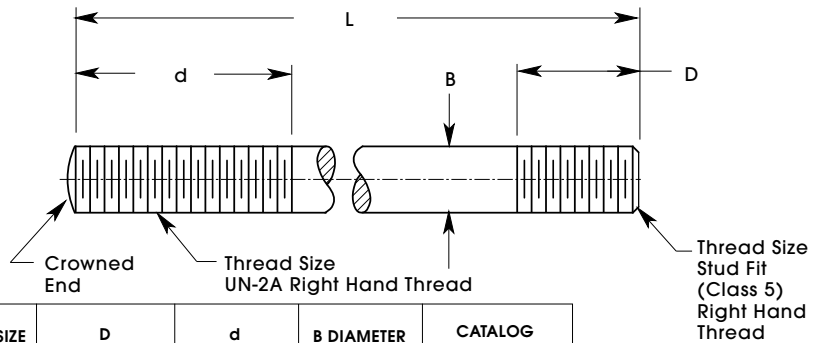

L	THREAD SIZE BOTH ENDS	D	d	B DIAMETER	CATALOG NUMBER
1	#6-32	7/32	1/2	.138	SEVP-1
1-1/4			5/8		SEVP-2
1-1/2			3/4		SEVP-30
1-3/4			3/4		SEVP-3
2			3/4		SEVP-4
1	#8-32	7/32	1/2	.164	SEVP-5
1-1/4			5/8		SEVP-6
1-1/2			3/4		SEVP-7
1-3/4			3/4		SEVP-8
2			3/4		SEVP-9
1	#10-24	7/32	1/2	.190	SEVP-10
1-1/4			5/8		SEVP-11
1-1/2			3/4		SEVP-12
1-3/4			3/4		SEVP-13
2			3/4		SEVP-31
1	#10-32	7/32	1/2	.190	SEVP-14
1-1/4			5/8		SEVP-15
1-1/2			3/4		SEVP-16
1-3/4			3/4		SEVP-17
2			3/4		SEVP-18
1-1/4	1/4-20	9/32	5/8	.250	SEVP-19
1-1/2			5/8		SEVP-20
1-3/4			3/4		SEVP-21
2			3/4		SEVP-22
2-1/2			3/4		SEVP-23
3	1	SEVP-24			
1-1/2	5/16-18	11/32	5/8	.312	SEVP-25
2			1		SEVP-26
2-1/2			1-1/4		SEVP-27
3			1-3/8		SEVP-28
3-1/2			1-1/2		SEVP-32
4			1-1/2		SEVP-29

THREADED STAINLESS ROD

303 Stainless Steel
Class 2A Thread
Threads #2-56 thru 1/2-20

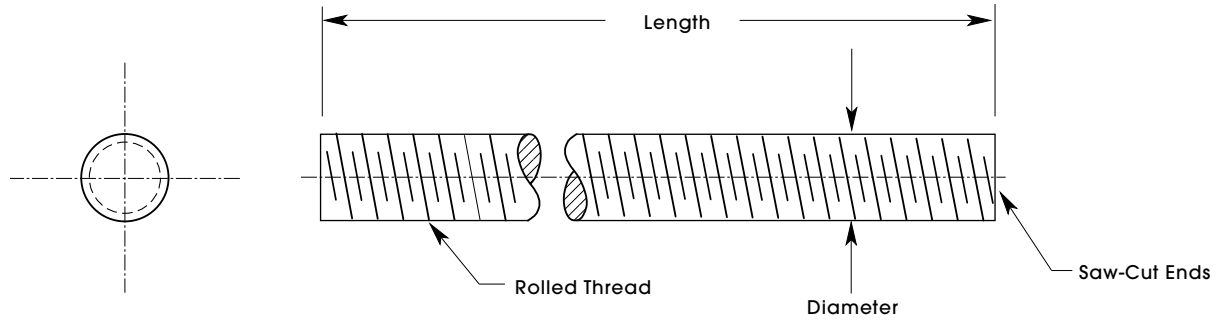

THREAD SIZE	LENGTH	DIAMETER	THREAD PITCH	CATALOG NUMBER
# 2-56	12	.086	.018	TSS-1
# 4-40	12	.112	.025	TSS-2
# 4-40	24	.112	.025	TSS-14
# 6-32	12	.138	.031	TSS-3
# 6-32	24	.138	.031	TSS-15
# 8-32	12	.164	.031	TSS-4
# 8-32	24	.164	.031	TSS-16
# 10-24	16	.190	.042	TSS-5
# 10-24	24	.190	.042	TSS-17
# 10-32	16	.190	.031	TSS-6
# 10-32	24	.190	.031	TSS-18
1/4-20	24	1/4	.050	TSS-7
1/4-28	24	1/4	.036	TSS-8
5/16-18	24	5/16	.055	TSS-9
5/16-24	24	5/16	.042	TSS-19
3/8-16	24	3/8	.062	TSS-10
3/8-24	24	3/8	.042	TSS-20
3/8-32	24	3/8	.031	TSS-11
1/2-13	36	1/2	.077	TSS-12
1/2-20	36	1/2	.050	TSS-13

HEX NUTS

Thread #00-96 thru 1/4-20
Stainless • Nylon

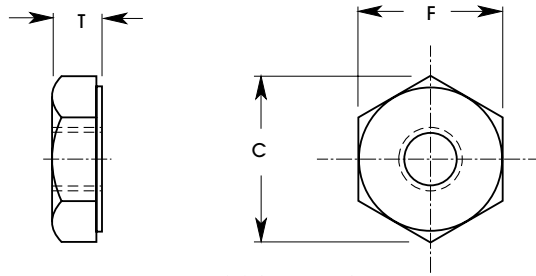

18-8 Stainless Steel

THREAD	T	C	F	CATALOG NUMBER
#00-96	3/64	7/64	3/32	SE5Y-00
#0-80	3/64	3/16	5/32	SE5Y-0
#1-64	3/64	3/16	5/32	SE5Y-164
#1-72	3/64	3/16	5/32	SE5Y-1
#2-56	1/16	7/32	3/16	SE5Y-2
#4-40	3/32	9/32	1/4	SE5Y-4
#6-32	7/64	23/64	5/16	SE5Y-6
#8-32	1/8	25/64	5/16	SE5Y-8

18-8 Stainless Steel

THREAD	T	C	F	CATALOG NUMBER
#10-24	1/8	7/16	3/8	SE5Y-11
#10-32	1/8	7/16	3/8	SE5Y-10
1/4-20	3/16	1/2	7/16	SE5Y-12
1/4-28	3/16	1/2	7/16	SE5Y-23
5/16-18	17/64	37/64	1/2	SE5Y-13
5/16-24	17/64	37/64	1/2	SE5Y-14
3/8-16	21/64	41/64	9/16	SE5Y-15
3/8-24	21/64	41/64	9/16	SE5Y-16
3/8-32	3/32	41/64	9/16	SE5Y-24

Nylon

THREAD	T	C	F	CATALOG NUMBER
#2-56	.066	.217	3/16	SE5ZN-2
#4-40	.098	.289	1/4	SE5ZN-1
#6-32	.114	.361	5/16	SE5ZN-3
#8-32	.130	.397	11/32	SE5ZN-5
#10-24	.130	.433	3/8	SE5ZN-7
#10-32	.130	.433	3/8	SE5ZN-9
1/4-20	.226	.505	7/16	SE5ZN-11

Sold in Packs of 10

WASHERS

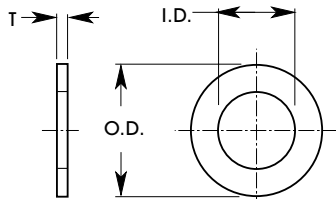

303 Stainless Steel

THREAD	I.D.	O.D.	T	CATALOG NUMBER
#4	.116	1/4	1/16	SE5CP-1
#6	.144	5/16	1/16	SE5CP-2
#8	.169	3/8	1/16	SE5CP-3
#10	.196	7/16	5/64	SE5CP-4
1/4	.257	1/2	5/64	SE5CP-5
5/16	.323	5/8	3/32	SE5CP-6
3/8	.386	3/4	3/32	SE5CP-7

Sold in Packs of 10

PER ANSI B18.22.1 1965 (R1975)

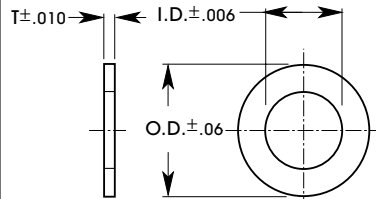

18-8 Stainless Steel

THREAD	O.D.	I.D.	T	CATALOG NUMBER
#0	.156	.062	.020	SE4Z-0
#2	.187	.089	.031	SE4Z-2
#4	.312	.125	.031	SE4Z-4
#6	.375	.149	.031	SE4Z-6
#8	.378	.174	.031	SE4Z-8
#10	.438	.203	.063	SE4Z-10
1/4	.500	.265	.063	SE4Z-12
3/8	.625	.390	.063	SE4Z-14
1/2	.750	.516	.093	SE4Z-15

Sold in Packs of 10

MIL-M 20693 COMP-A (WHITE)

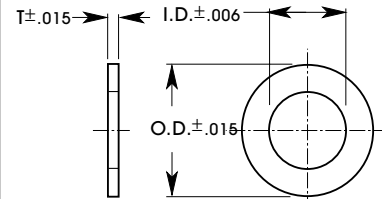

Nylon

SCREW SIZE	O.D.	I.D.	T	CATALOG NUMBER
#4	.281	.115	.047	SE4ZN-1
#6	.312	.140	.047	SE4ZN-3
#8	.375	.170	.062	SE4ZN-5
#10	.427	.200	.062	SE4ZN-7
1/4	.562	.260	.062	SE4ZN-9

Sold in Packs of 10

PER ASME B18.22.1 1990

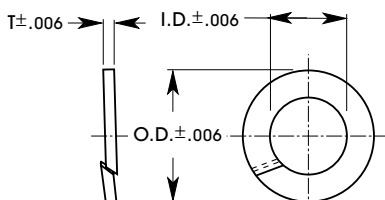

Stainless Steel

THREAD	O.D.	I.D.	T	CATALOG NUMBER
#0	.110	.066	.020	SE3Z-0
#2	.166	.093	.020	SE3Z-2
#4	.203	.120	.025	SE3Z-4
#6	.244	.146	.031	SE3Z-6
#8	.287	.173	.040	SE3Z-8
#10	.327	.199	.047	SE3Z-10
1/4	.483	.261	.062	SE3Z-12
3/8	.676	.390	.094	SE3Z-14
1/2	.875	.531	.125	SE3Z-15

Sold in Packs of 10

PER ANSI B18.22.1 1965 (R1975)

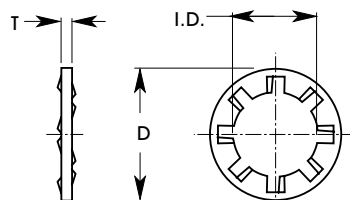

410 Stainless Steel

THREAD	D	I.D.	T	CATALOG NUMBER
#2	.185	.093	.013	SE2Z-2
#4	.265	.120	.015	SE2Z-4
#6	.288	.146	.018	SE2Z-6
#8	.336	.173	.020	SE2Z-8
#10	.381	.200	.022	SE2Z-10
1/4	.478	.260	.025	SE2Z-25
5/16	.607	.326	.030	SE2Z-31
3/8	.692	.390	.035	SE2Z-37
1/2	.883	.530	.090	SE2Z-50

Sold in Packs of 10

PER ANSI B18.22.1 1965 (R1975)

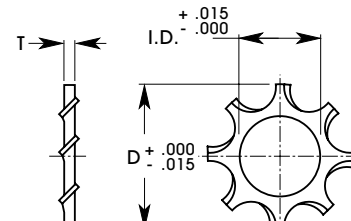

410 Stainless Steel

THREAD	D	I.D.	T	CATALOG NUMBER
#4	.255	.120	.015	SE1Z-4
#6	.317	.146	.018	SE1Z-6
#8	.381	.173	.020	SE1Z-8
#10	.406	.200	.022	SE1Z-10
1/4	.506	.260	.025	SE1Z-25
5/16	.601	.326	.030	SE1Z-31
3/8	.695	.390	.035	SE1Z-37
1/2	.898	.530	.040	SE1Z-50

Sold in Packs of 10

THRUST WASHERS

Bronze • Stainless Steel • Carbon Steel
Nylon • Tool Steel

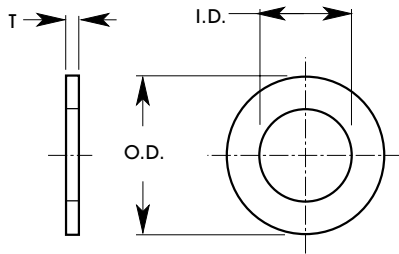
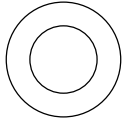

Bronze Oil-Impregnated / Tool Steel

I.D.	O.D. BRONZE	O.D. TOOL STEEL	T	SHAFT SIZE	CATALOG NUMBER/MATL	
					440 STAINLESS STEEL	CARBON STEEL
.128	.372	.252	.062	1/8	SE3DC-1	SE5DC-1
.190	.497	.377	.062	3/16	SE3DC-2	SE5DC-2
.253	.622	.502	.062	1/4	SE3DC-3	SE5DC-3
.316	.747	.627	.093	5/16	SE3DC-4	SE5DC-4
.378	.872	.752	.125	3/8	SE3DC-5	SE5DC-5
.503	1.127	1.002	.187	1/2	SE3DC-6	SE5DC-6

Hardened and Ground Washers

I.D.	O.D.	T	SHAFT SIZE	CATALOG NUMBER/MATL	
				440 STAINLESS STEEL	CARBON STEEL
1/8	7/16	.049	1/8	SE1DCSS-1	SE1DC-1
3/16	1/2	.049	3/16	SE1DCSS-2	SE1DC-2
1/4	9/16	.049	1/4	SE1DCSS-3	SE1DC-3
5/16	5/8	.049	5/16	SE1DCSS-4	SE1DC-4
3/8	13/16	.062	3/8	SE1DCSS-5	SE1DC-5
1/2	15/16	.062	1/2	SE1DCSS-6	SE1DC-6
5/8	1-1/8	.093	5/8	SE1DCSS-7	SE1DC-7
3/4	1-1/4	.093	3/4	SE1DCSS-8	SE1DC-8
1	1-5/8	.125	1	SE1DCSS-9	SE1DC-9

Nylon Thrust Washers

I.D.	O.D.	T	SHAFT SIZE	CATALOG NUMBER
.188	3/4	.062	3/16	SE7DC-3
.250	5/8	.093	1/4	SE7DC-4
.500	13/16	.093	1/2	SE7DC-5
.625	1-1/16	.093	5/8	SE7DC-10
.750	1-1/8	.093	3/4	SE7DC-12

SWIVEL WASHER

303 Stainless Steel — Machined
Screw Size #4 thru 3/8

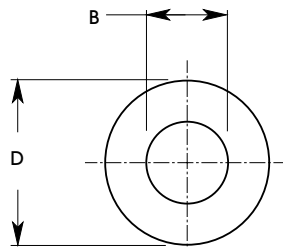
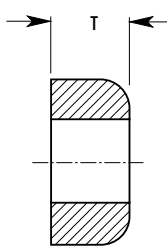
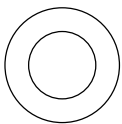

Type 1

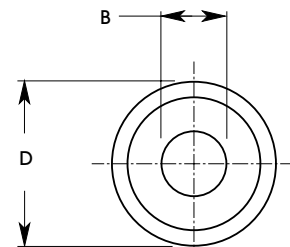
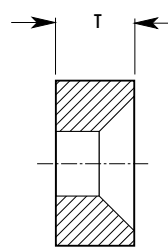

Type 2

THREAD	D.	B.	T	CATALOG NUMBER	ASSEMBLED HEIGHT	D.	B.	T	CATALOG NUMBER
#4	9/32	.116	1/8	SE6CP-1	13/64	3/8	5/32	1/8	SE7CP-1
#6	9/32	.144	1/8	SE6CP-2	13/64	3/8	11/64	1/8	SE7CP-2
#8	5/16	.169	1/8	SE6CP-3	13/64	3/8	3/16	1/8	SE7CP-3
#10	3/8	.196	5/32	SE6CP-4	15/64	1/16	7/32	1/8	SE7CP-4
1/4	7/16	.257	3/16	SE6CP-5	17/64	1/2	9/32	5/32	SE7CP-5
5/16	1/2	.323	3/16	SE6CP-6	21/64	9/16	11/32	3/16	SE7CP-6
3/8	5/8	.386	1/4	SE6CP-7	25/64	11/16	13/32	1/4	SE7CP-7

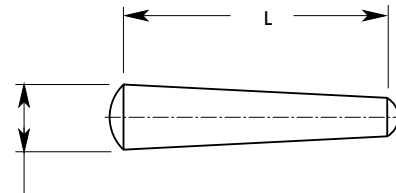
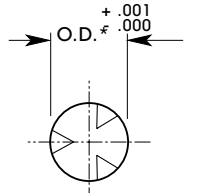
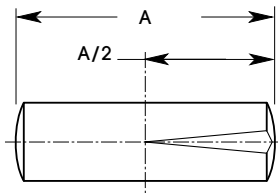

Grooved Pins
303 Stainless Steel
1/2 Length Type B
ANSI-B18.8.2-1978 (R1989)

O.D	DRILL SIZE	A	CATALOG NUMBER
.0469 \pm .0000 -.0010	3/64	3/8	SH14-7
		1/2	SH14-8
		5/8	SH14-13
.0625 \pm .0000 -.0010	1/16	3/8	SH14-9
		1/2	SH14-10
		5/8	SH14-14
.0781 \pm .0000 -.0010	5/64	3/8	SH14-15
		1/2	SH14-16
		5/8	SH14-17
.0938 \pm .0000 -.0010	3/32	3/8	SH14-11
		1/2	SH14-12
.0938 \pm .0000 -.0010	3/32	5/8	SH14-18
		3/4	SH14-19
.1250 \pm .0000 -.0020	1/8	1/2	SH14-20
		5/8	SH14-21
		3/4	SH14-22
		1	SH14-23
.1563 \pm .0000 -.0020	5/32	1/2	SH14-24
		5/8	SH14-25
		3/4	SH14-26
		1	SH14-27

Taper Pins
303 Stainless Steel
Taper 1/4" per Foot
ANSI-B18.8.2-1978 (R1989)

TAPER PIN NUMBER	DIAMETER	L	CATALOG NUMBER
#9/0	.031	1/4	SE13-6
		3/8	SE13-7
#8/0	.047	1/4	SE13-8
		3/8	SE13-1
		1/2	SE13-2
#97/0	.0625	3/8	SE13-9
		7/16	SE13-3
		1/2	SE13-4
		5/8	SE13-10
#6/0	.078	7/16	SE13-11
		1/2	SE13-12
		9/16	SE13-13
#5/0	.094	9/16	SE13-5
		5/8	SE13-14
#4/0	.109	3/4	SE13-15
		1	SE13-16
#3/0	.125	5/8	SE13-17
		3/4	SE13-18

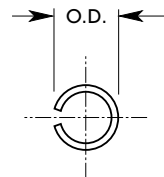
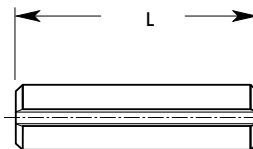

Roll Pins
420 Stainless Steel

O.D	DRILL SIZE	REF. SHAFT DIA.	A	CATALOG NUMBER
.069	1/16	3/16	1/4	SH17-4
			5/16	SH17-5
			3/8	SH17-1
			7/16	SH17-2
			1/2	SH17-3
			9/16	SH17-6
			5/8	SH17-7
.086	5/64	1/4	9/16	SH17-8
.103	5/64	1/4	3/8	SH17-9
			7/16	SH17-10
.103	3/32	1/4	1/2	SH17-11
			5/8	SH17-12
.135	1/8	3/8	3/8	SH17-13
			7/16	SH17-14
			1/2	SH17-15
			9/16	SH17-16
			5/8	SH17-17
			11/16	SH17-18
.167	5/32	1/2	3/4	SH17-19
			1/2	SH17-20

PINS

Spirol • Cotter
All Sold in Packs of 10

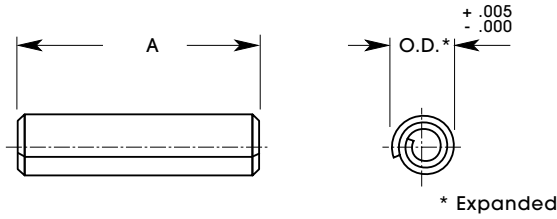

Spirol Pins 303 Stainless Steel

O.D	DRILL SIZE	REF. SHAFT	A	CATALOG NUMBER
.033 +.002 -.000	.031	3/32	1/8	SH14-28
			3/16	SH14-29
			1/4	SH14-30
			5/16	SH14-31
			3/8	SH14-32
.041 +.003 -.000	.039	1/8	3/16	SH14-33
			1/4	SH14-34
			5/16	SH14-1
			7/16	SH14-35
.049 +.003 -.000	.047	1/8	3/16	SH14-36
			1/4	SH14-37
			5/16	SH14-38
			3/8	SH14-39
			7/16	SH14-40
.054 +.003 -.000	.051	1/8	1/2	SH14-41
			3/16	SH14-42
			1/4	SH14-43
			5/16	SH14-44
			3/8	SH14-45
7/16	SH14-46	1/2	SH14-47	

O.D	DRILL SIZE	REF. SHAFT	A	CATALOG NUMBER
.067 +.005 -.000	.061	3/16	1/4	SH14-48
			5/16	SH14-49
			3/8	SH14-3
			7/16	SH14-50
			1/2	SH14-4
			9/16	SH14-51
.083 +.005 -.000	.077	1/4	5/8	SH14-52
			1/4	SH14-53
.099 +.006 -.000	.093	1/4 & 5/16	3/8	SH14-5
			7/16	SH14-54
			1/2	SH14-6
			9/16	SH14-55
			5/8	SH14-56
.131 +.007 -.000	.124	3/8 7/16 & 1/2	11/16	SH14-57
			3/8	SH14-58
			7/16	SH14-59
			1/2	SH14-60
			9/16	SH14-61
			5/8	SH14-62
			11/16	SH14-63
3/4	SH14-64			
1	SH14-65			

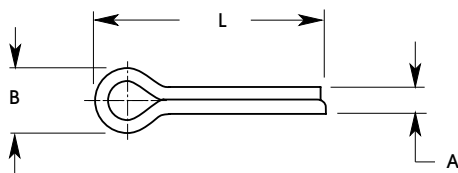

Cotter Pins
Stainless Steel
ANSI-B18.8.1-1972 (R1983)

A	B MIN	HOLE SIZE	L	CATALOG NUMBER
.032	1/16	3/64	3/8	SE1PC-31
			1/2	SE1PC-32
			3/4	SE1PC-1
			1	SE1PC-34
.048	3/32	1/16	1	SE1PC-2
.060	1/8	5/64	3/8	SE1PC-35
			1/2	SE1PC-36
			3/4	SE1PC-37
			1	SE1PC-3
			1-1/2	SE1PC-9
.076	5/32	3/32	1-1/4	SE1PC-4
.090	3/16	7/64	1/2	SE1PC-10
			3/4	SE1PC-11
			1	SE1PC-12
			1-1/2	SE1PC-5
.120	1/4	9/64	1/2	SE1PC-14
			3/4	SE1PC-15
			1	SE1PC-16
			1-1/2	SE1PC-17
			2	SE1PC-7
.150	5/16	11/64	3/4	SE1PC-19
			1	SE1PC-20
			1-1/2	SE1PC-21

PRECISION DOWELS PINS

Diameter .0312 thru .3750

Lengths 3/32 thru 1-1/2

Sold in Packs of 10

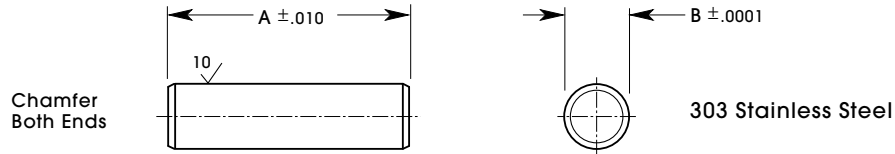

A	CATALOG NUMBER/ B							
	(1/32") .0312	(1/16") .0625	(5/64") .0780	(3/32") .0937	(1/8") .1250	(5/32") .1561	(3/16") .1874	(1/4") .2499
3/32	SH16-1	SH16-14	SH16-80	SH16-27	SH16-40	----	----	----
1/8	SH16-2	SH16-15	SH16-81	SH16-28	SH16-41	----	----	----
5/32	SH16-3	SH16-16	SH16-82	SH16-29	SH16-42	----	----	----
3/16	SH16-4	SH16-17	SH16-83	SH16-30	SH16-43	SH16-53	----	----
7/32	SH16-5	SH16-18	SH16-01	SH16-31	SH16-44	SH16-00	----	----
1/4	SH16-6	SH16-19	SH16-84	SH16-32	SH16-45	SH16-54	SH16-60	----
5/16	SH16-7	SH16-20	SH16-85	SH16-33	SH16-46	SH16-55	SH16-61	----
3/8	SH16-8	SH16-21	SH16-86	SH16-34	SH16-47	SH16-56	SH16-62	SH16-68
7/16	SH16-9	SH16-22	SH16-87	SH16-35	SH16-48	SH16-57	SH16-63	SH16-69
1/2	SH16-10	SH16-23	----	SH16-36	SH16-49	SH16-58	SH16-64	SH16-70
5/8	SH16-11	SH16-24	----	SH16-37	SH16-50	SH16-59	SH16-65	SH16-71
3/4	SH16-12	SH16-25	----	SH16-38	SH16-51	----	SH16-66	SH16-72
7/8	SH16-13	SH16-26	----	SH16-39	SH16-52	----	SH16-67	SH16-73
1	SH16-88	SH16-89	----	SH16-90	SH16-91	----	SH16-92	SH16-93

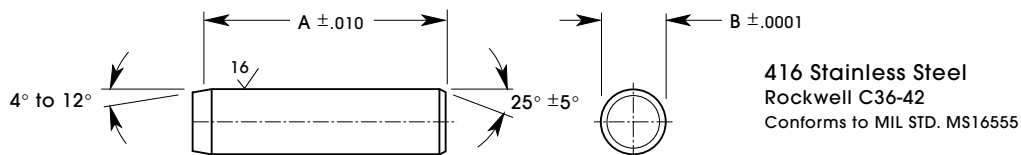

A	CATALOG NUMBER/ B							
	.0627	.0940	.1250	.1564	.1877	.2502	.3127	.3752
3/16	SE32D-1	SE33D-1	----	----	----	----	----	----
1/4	SE32D-2	SE33D-2	SE34D-2	----	----	----	----	----
5/16	SE32D-15	SE33D-15	SE34D-15	----	----	----	----	----
3/8	SE32D-3	SE33D-3	SE34D-3	SE35D-3	SE36D-3	----	----	----
7/16	SE32D-17	SE33D-17	SE34D-17	SE35D-17	----	----	----	----
1/2	SE32D-4	SE33D-4	SE34D-4	SE35D-4	SE36D-4	SE37D-4	----	----
5/8	SE32D-5	SE33D-5	SE34D-5	SE35D-5	SE36D-5	SE37D-5	SE38D-5	----
3/4	SE32D-6	SE33D-6	SE34D-6	SE35D-6	SE36D-6	SE37D-6	SE38D-6	SE39D-6
7/8	SE32D-7	SE33D-7	SE34D-7	SE35D-7	----	----	----	----
1	SE32D-8	SE33D-8	SE34D-8	SE35D-8	SE36D-8	SE37D-8	SE38D-8	SE39D-8
1-1/4	----	----	----	----	SE36D-9	SE37D-9	SE38D-9	SE39D-9
1-1/2	----	----	----	----	----	SE37D-10	SE38D-10	SE39D-10

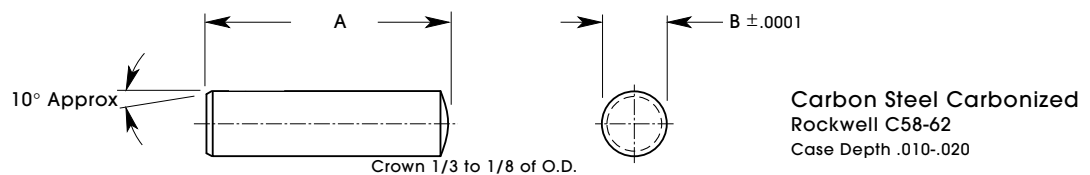

A	CATALOG NUMBER/ B						
	.0627	.0940	.1250	.1877	.2502	.3127	.3752
3/16	SE1D-1	----	----	----	----	----	----
1/4	SE1D-2	SE2D-2	----	----	----	----	----
3/8	SE1D-3	SE2D-3	SE3D-3	----	----	----	----
1/2	SE1D-4	SE2D-4	SE3D-4	SE4D-4	SE5D-4	SE6D-4	SE7D-4
5/8	SE1D-5	SE2D-5	SE3D-5	SE4D-5	SE5D-5	SE6D-5	SE7D-5
3/4	SE1D-6	SE2D-6	SE3D-6	SE4D-6	SE5D-6	SE6D-6	SE7D-6
7/8	SE1D-7	SE2D-7	SE3D-7	SE4D-7	SE5D-7	SE6D-7	SE7D-7
1	SE1D-8	SE2D-8	SE3D-8	SE4D-8	SE5D-8	SE6D-8	SE7D-8
1-1/4	----	----	SE3D-9	SE4D-9	SE5D-9	SE6D-9	SE7D-9
1-1/2	----	SE2D-10	SE3D-10	SE4D-10	SE5D-10	SE6D-10	SE7D-10

RETAINER RINGS

External • Internal

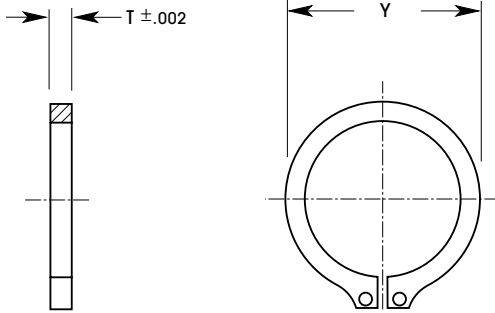
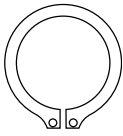

External Lug Style

SS - Ph 15-7 Mo
 BC - Beryllium Copper
 CP - Carbon Spring Steel Plated

SHAFT SIZE S	T	MATERIAL	Y RING I.D.	CATALOG NUMBER
1/8	.010	BC	.112	SH10-4
5/32 & 4mm	.010	BC	.112	SH10-7
3/16	.015	BC	.168	SH10-5
6mm	.015	BC	.215	SH10-8
1/4	.025	SS	.225	SH10-6
5/16 & 8mm	.025	SS	.281	SH10-9
11/32	.025	SS	.309	SH10-10
3/8	.025	SS	.338	SH10-11
10mm	.025	SS	.354	SH10-12
1/2	.035	SS	.461	SH10-13
1/2	.035	CP	.461	SH10-14
5/8 & 16mm	.035	SS	.579	SH10-15
5/8 & 16mm	.035	CP	.579	SH10-16
3/4 & 19mm	.042	SS	.693	SH10-17
7/8	.042	SS	.810	SH10-18
7/8	.042	CP	.810	SH10-19
1	.042	SS	.925	SH10-20
1-1/4 & 32mm	.050	SS	1.156	SH10-21
1-1/4 & 32mm	.050	CP	1.156	SH10-22
1-9/16	.062	SS	1.446	SH10-23
1-9/16	.062	CP	1.446	SH10-24

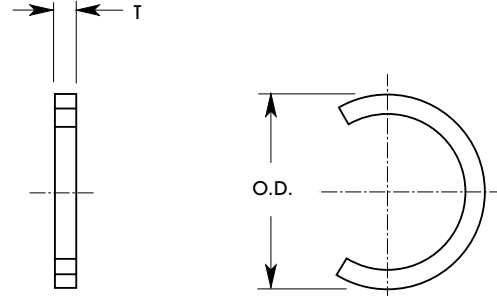

External Style

Carbon Steel • Ph 15-7 Mo Stainless Steel

SHAFT SIZE	O.D.	T	CATALOG NUMBER/MATL	
			CARBON STEEL	STAINLESS STEEL
1/2	.550	.035	SE5Q-1	SE5QSS-1
5/8	.673	.035	SE5Q-2	SE5QSS-2
7/8	.923	.042	SE5Q-3	SE5QSS-3
1-1/8	1.180	.050	SE5Q-4	SE5QSS-4
1-1/4	1.301	.050	SE5Q-5	SE5QSS-5

WIDTH + .005 - .000	DIAMETER + .005 - .000
.039	.468
.039	.588
.046	.821
.056	1.061
.056	1.176
.068	1.468
.068	1.886
.086	2.239

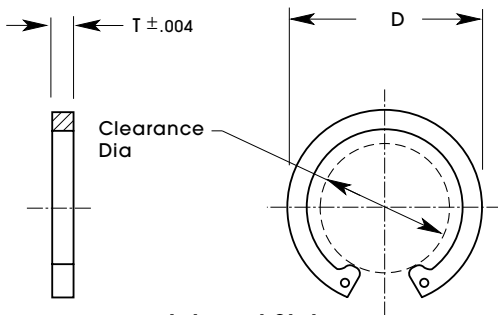

Internal Style 420 Stainless Steel

RING THICKNESS T	D	MAX. CLEAR. DIA.	T	CATALOG NUMBER
.015	.280	.133	.015	SH9-4
.015	.346	.191	.015	SH9-5
.025	.415	.226	.025	SH9-1
.035	.548	.290	.035	SH9-2
.035	.694	.380	.035	SH9-3
.035	.831	.490	.035	SH9-6
.042	.971	.600	.042	SH9-7
.042	1.111	.730	.042	SH9-8
.050	1.249	.815	.050	SH9-9

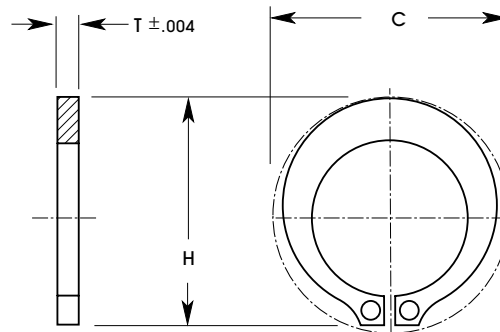

External Grip Style

Compression Fit*

Ph 15-7 Mo Stainless Steel

* This Style Does Not Require a Gooved Shaft

SHAFT SIZE S	T	H RING HEIGHT	CLEARANCE DIA C	CATALOG NUMBER
1/8	.025	.268	.33	SE7Q-21
5/32 & 4mm	.025	.307	.36	SE7Q-51
3/16	.035	.364	.44	SE7Q-81
1/4	.035	.437	.49	SE7Q-52
5/16 & 8mm	.042	.553	.68	SE7Q-13
3/8	.042	.620	.74	SE7Q-73
1/2	.050	.768	.90	SE7Q-05
3/4 & 19mm	.062	1.115	1.32	SE7Q-57

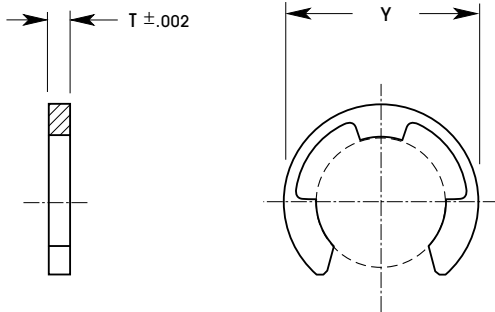

External Style

Ph 15-7 Mo Stainless Steel

SHAFT SIZE S	T	Y	CATALOG NUMBER
5/64	.012	.14	SH11-1
3/32	.017	.19	SH11-2
1/8	.017	.23	SH11-7
5/32 & 4mm	.027	.29	SH11-3
3/16	.027	.34	SH11-8
1/4	.027	.53	SH11-9
5/16 & 8mm	.027	.50	SH11-10
3/8	.037	.66	SH11-11
7/16 & 11mm	.037	.69	SH11-12
1/2	.044	.80	SH11-13
5/8 & 16mm	.044	.94	SH11-14
3/4 & 19mm	.052	1.12	SH11-15
7/8	.052	1.30	SH11-16
1	.052	1.50	SH11-17

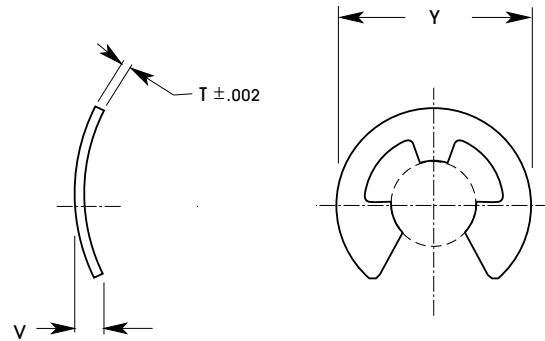

External Bowed Style

Ph 15-7 Mo Stainless Steel

SHAFT SIZE S	Y	T	V	CATALOG NUMBER
1/8	.230	.010	.025	SE3Q-21
3/16	.335	.015	.033	SE3Q-81
1/4	.527	.025	.052	SE3Q-52
5/16 & 8mm	.500	.025	.050	SE3Q-13
3/8	.660	.035	.060	SE3Q-73
1/2	.800	.042	.075	SE3Q-05
3/4 & 19mm	1.000	.050	.088	SE3Q-57

INTERNAL FRICTION FIT BEARING RETAINER

Carbon Spring Steel Plated
3/8" to 1-1/4" Housing Bore
Internal Push in Design

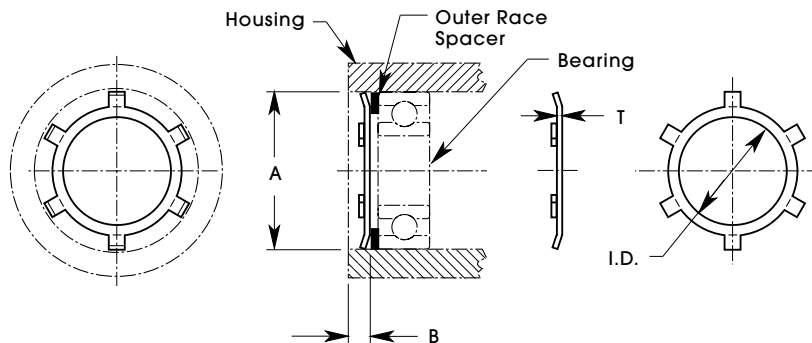

I.D. REF. ONLY	A HOUSING	B MIN. END SPACE	T ±.002	CATALOG NUMBER
3/16	3/8	.040	.010	SE6QCP-73
1/4	1/2	.060	.010	SE6QCP-05
3/8	5/8	.060	.010	SE6QCP-26
5/8	7/8	.080	.015	SE6QCP-78
15/16	1-1/4	.080	.015	SE6QCP-52

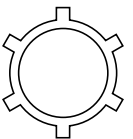

SHAFT SPACER *PRECISION*

Inner Race

Stainless Steel • Anodized Aluminum

Shaft Size 5/64" to 1/2"

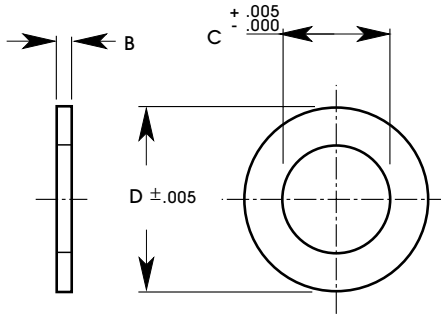
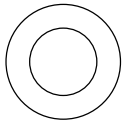

C	D	B	CATALOG NUMBER/MATL	
			STAINLESS STEEL	ALUMINUM
.079	.164	.002	EH1-70	---
		.004 ±.001	EH1-71	---
		.006	EH1-72	---
		.008	EH1-73	---
		.010	EH1-74	---
		.012 ±.002	EH1-75	---
		.014	EH1-76	---
.093	.203	.002	EH1-78	---
		.004 ±.001	EH1-79	---
		.006	EH1-80	---
		.008	EH1-81	---
		.010	EH1-82	---
		.012 ±.002	EH1-83	---
		.014	EH1-84	---
.125	.187	.002	EH1-86	---
		.004 ±.001	EH1-1	---
		.006	EH1-2	---
		.008	EH1-3	---
		.010	EH1-4	---
		.012 ±.002	EH1-5	---
		.014	EH1-6	---
		.016	EH1-7	---
		.031	EH1-8	EH1-08A
		.063 ±.003	EH1-9	EH1-09A
		.094	EH1-10	EH1-10A
		.125	EH1-11	EH1-11A
		.188	EH1-12	EH1-12A
		.250	EH1-13	EH1-13A
.375	EH1-14	EH1-14A		
.500	EH1-15	EH1-15A		
.187	.250	.002	EH1-87	----
		.004 ±.001	EH1-24	----
		.006	EH1-25	----
		.008	EH1-26	----
		.010	EH1-27	----
		.012 ±.002	EH1-28	----
		.014	EH1-29	----
		.016	EH1-30	----
		.031	EH1-31	EH1-31A
		.063 ±.003	EH1-32	EH1-32A
		.094	EH1-33	EH1-33A
		.125	EH1-34	EH1-34A
		.188	EH1-35	EH1-35A
		.250	EH1-36	EH1-36A
.375	EH1-37	EH1-37A		
.500	EH1-38	EH1-38A		

C	D	B	CATALOG NUMBER/MATL	
			STAINLESS STEEL	ALUMINUM
.250	.375	.002	EH1-90	----
		.004 ±.001	EH1-47	----
		.006	EH1-48	----
		.008	EH1-49	----
		.010	EH1-50	----
		.012 ±.002	EH1-51	----
		.014	EH1-52	----
		.016	EH1-53	----
		.031	EH1-54	EH1-54A
		.063 ±.003	EH1-55	EH1-55A
		.094	EH1-56	EH1-56A
		.125	EH1-57	EH1-57A
		.188	EH1-58	EH1-58A
		.250	EH1-59	EH1-59A
.375	EH1-60	EH1-60A		
.500	EH1-61	EH1-61A		
.313	.500	.002	EH1-91	----
		.004 ±.001	EH1-92	----
		.006	EH1-93	----
		.008	EH1-94	----
		.010	EH1-95	----
		.012 ±.002	EH1-96	----
		.014	EH1-97	----
		.016	EH1-98	----
		.031	EH1-99	----
		.062 ±.003	EH1-100	----
		.125	EH1-101	----
.375	.562	.002	EH1-102	----
		.004 ±.001	EH1-103	----
		.006	EH1-104	----
		.008	EH1-105	----
		.010	EH1-106	----
		.012 ±.002	EH1-107	----
		.014	EH1-108	----
		.016	EH1-109	----
		.031	EH1-110	EH1-110A
		.063 ±.003	EH1-111	EH1-111A
		.094	EH1-112	EH1-112A
.125	EH1-113	EH1-113A		
.188	EH1-114	EH1-114A		
.250	EH1-115	EH1-115A		
.375	EH1-116	EH1-116A		
.500	EH1-117	EH1-117A		
.500	.750	.002	EH1-118	----
		.004 ±.001	EH1-119	----
		.006	EH1-120	----
		.008	EH1-121	----
		.010	EH1-122	----
		.012 ±.002	EH1-123	----
		.014	EH1-124	----
		.016	EH1-125	----
		.031	EH1-126	----
		.062 ±.003	EH1-127	----
		.125	EH1-128	----

PRECISION SHAFT SPACER

Outer Race
Stainless Steel • Anodized Aluminum
5/32" to 1-1/8" Bearing Diameter

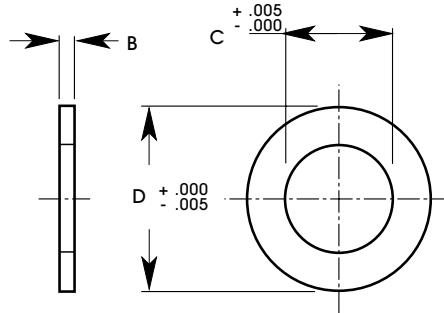

D	C	B	CATALOG NUMBER/MATL	
			STAINLESS STEEL	ALUMINUM
.153	.088	.003	SH12-20	----
		.005 ±.001	SH12-21	----
		.007	SH12-22	----
		.010 ±.002	SH12-23	----
.178	.123	.010	SH12-24	----
		.020	SH12-25	----
		.003 ±.001	SH12-26	----
		.005 ±.001	SH12-27	----
.248	.167	.007	SH12-28	----
		.010 ±.002	SH12-29	----
		.020	SH12-30	----
		.003 ±.001	SH12-31	----
.310	.206	.005 ±.001	SH12-32	----
		.007	SH12-33	----
		.010 ±.002	SH12-34	----
		.020	SH12-35	----
.373	.253	.003 ±.001	SH12-36	----
		.005 ±.001	SH12-37	----
		.007	SH12-38	----
		.010 ±.002	SH12-39	----
.498	.378	.010 ±.002	SH12-1	----
		.020	SH12-2	----
		.003 ±.001	SH12-3	----
		.005 ±.001	SH12-4	----
		.007	SH12-5	----
		.032 ±.003	SH12-70	SH12-70A
		.062	SH12-71	SH12-71A
		.125	SH12-72	SH12-72A
		.250	SH12-73	SH12-73A
		.375	SH12-74	SH12-74A
.500	SH12-75	SH12-75A		
.498	.378	.003 ±.001	SH12-6	----
		.005 ±.001	SH12-7	----
		.007	SH12-8	----
		.010 ±.002	SH12-9	----
		.020	SH12-10	----

D	C	B	CATALOG NUMBER/MATL	
			STAINLESS STEEL	ALUMINUM
.498	.378	.032	SH12-40	SH12-40A
		.062	SH12-41	SH12-41A
		.125 ±.003	SH12-42	SH12-42A
		.250	SH12-43	SH12-43A
		.375	SH12-44	SH12-44A
.623	.503	.500	SH12-45	SH12-45A
		.003 ±.001	SH12-11	----
		.005 ±.001	SH12-12	----
		.007	SH12-13	----
		.010 ±.002	SH12-14	----
		.020	SH12-15	----
		.032 ±.003	SH12-46	SH12-46A
		.062	SH12-47	SH12-47A
		.125	SH12-48	SH12-48A
		.250	SH12-49	SH12-49A
.685	.562	.375	SH12-50	SH12-50A
		.500	SH12-51	SH12-51A
		.016 ±.002	SH12-52	----
		.032 ±.003	SH12-53	----
.873	.687	.062	SH12-54	----
		.003 ±.001	SH12-55	----
		.005 ±.001	SH12-56	----
		.007	SH12-57	----
		.010 ±.002	SH12-58	----
		.016 ±.002	SH12-59	----
		.020	SH12-60	----
		.032 ±.003	SH12-61	SH12-61A
		.062	SH12-62	SH12-62A
		.125	SH12-63	SH12-63A
.250	SH12-64	SH12-64A		
1.120	.937	.375	SH12-65	SH12-65A
		.500	SH12-66	SH12-66A
		.016 ±.002	SH12-67	----
		.032 ±.003	SH12-68	----
		.062	SH12-69	----

WASHER BELLEVILLE

302 Stainless Steel • 1095 Carbon Steel
 3/32" TO 3/4" Shaft size
 3/16" to 1-1/2" Outside Diameter

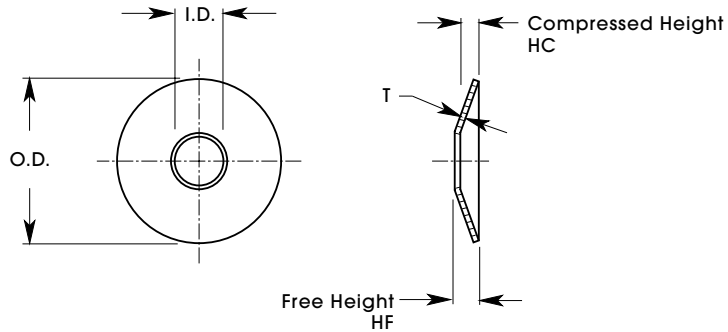
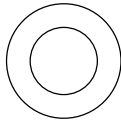

O.D. ±.010	I.D. + .000 - .005	T ±10%	HF REF	HC	FORCE TO COMPRESS TO HC ±15%	CATALOG NUMBER
.187	.093	.010	.015	.012	15 LBS	SETS-1
.250	.125	.013	.020	.017	26 LBS	SETS-2
.312	.156	.016	.025	.021	41 LBS	SETS-3
.375	.190	.020	.030	.025	60 LBS	SETS-4
.500	.255	.025	.038	.031	95 LBS	SETS-5
.625	.317	.032	.048	.040	145 LBS	SETS-6
.750	.380	.040	.059	.049	235 LBS	SETS-7
1.000	.505	.050	.075	.062	340 LBS	SETS-8
1.250	.630	.062	.092	.077	475 LBS	SETS-9
1.500	.750	.072	.107	.089	660 LBS	SETS-10*

* 1095 Carbon Steel

SHIM SPACER LAMINATED

Brass

1/8" to 3/8" SHAFTS

Mil-S 22499C Comp. 2 Type 1 Cl. -1

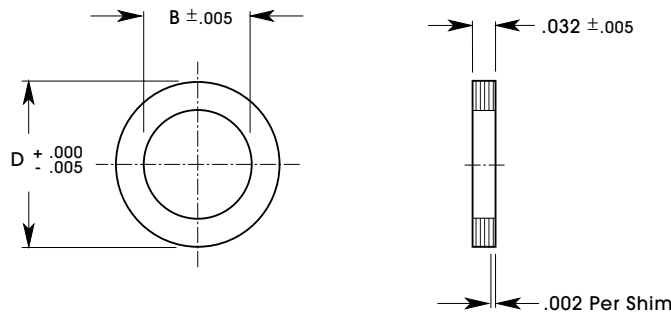

SHAFT SIZE	D	B	CATALOG NUMBER
1/8	.234	.135	SH15-1
3/16	.375	.193	SH15-2
1/4	.500	.255	SH15-3
3/8	.625	.380	SH15-9

D	B	CATALOG NUMBER
.375	.281	SH15-4
.498	.343	SH15-5
.623	.437	SH15-6
.873	.687	SH15-8

BEARING PRELOAD SPRINGS

302 Stainless Steel Spring Tempered
for Outer Race Ball Bearing Preloading

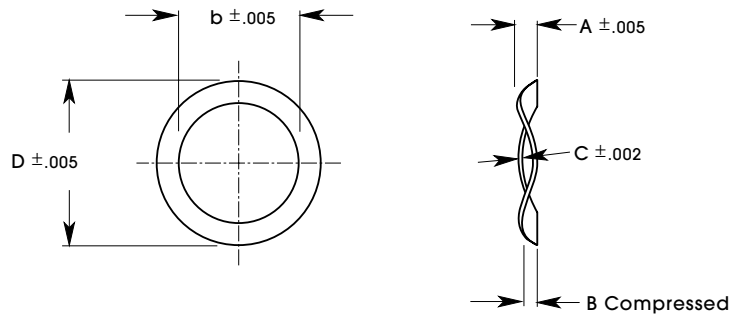

BEARING O.D. REF	D	d	A	B	C	LOAD IN LBS TO DEFLECT TO B	CATALOG NUMBER
.3750	.367	.265	.030	.015	.006	2-4	SEVS-7
.5000	.492	.350	.035	.020	.007	3-5	SEVS-8
.6250	.618	.440	.040	.025	.008	3-5	SEVS-9
.7500	.734	.531	.050	.030	.009	4-7	SEVS-4
.8750	.855	.650	.060	.030	.010	4-7	SEVS-5
1.1250	1.102	.856	.075	.037	.012	9-13	SEVS-6

CURVED WASHER

302 Stainless Steel • 1095 Carbon Steel
1/8" TO 1/2" Shaft size
1/4" to 1" Outside Diameter

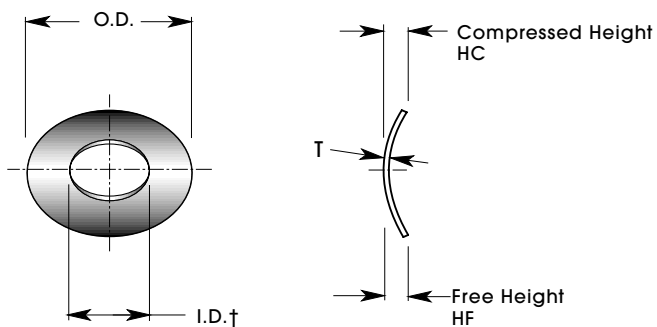

†I.D. Based on Long Axis Providing Free Fit on Normal Screw

SCREW OR ROD SIZE	HOLE SIZE	O.D. ±.010	I.D.	HF REF.	T ±10%	HC	FORCE TO COMPRESS TO HC ±15%	CATALOG NUMBER
#5	1/4	.245	.135	.034	.006	.020	2 LBS	SEVU-1
#6	9/32	.270	.148	.035	.007	.025	3 LBS	SEVU-2
#8	11/32	.322	.174	.042	.007	.025	3 LBS	SEVU-3
#10	3/8	.370	.200	.047	.009	.028	4 LBS	SEVU-4
#12	7/16	.423	.231	.053	.010	.032	5 LBS	SEVU-5
1/4	1/2	.490	.265	.063	.011	.034	7 LBS	SEVU-6
9/32	9/16	.551	.296	.070	.012	.038	8 LBS	SEVU-7*
5/16	5/8	.612	.327	.077	.013	.042	9 LBS	SEVU-8
11/32	11/16	.672	.363	.081	.015	.047	11 LBS	SEVU-9*
3/8	3/4	.735	.395	.086	.016	.050	12 LBS	SEVU-10
7/16	7/8	.857	.462	.100	.018	.057	12 LBS	SEVU-11*
1/2	1	.980	.525	.110	.021	.063	20 LBS	SEVU-12

* 1095 Carbon Steel

BALLS HARDENED STEEL

416 Stainless Steel Grade #50
 1/16" TO 1/2" Diameter
 C55 to C62 – Rockwell

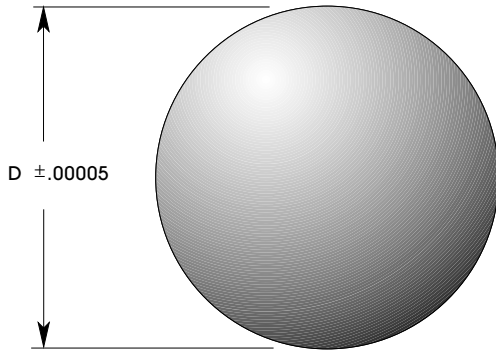
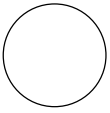

D	CATALOG NUMBER
1/16	SE4TP-2
3/32	SE4TP-3
1/8	SE4TP-4
5/32	SE4TP-5
3/16	SE4TP-6
1/4	SE4TP-8
5/16	SE4TP-10
3/8	SE4TP-12
1/2	SE4TP-16

Sold in Packs of 10

BALLS PLASTIC

Nylon • Teflon
 1/16" to 1/2" Diameter
 Ideal for Float, Check, Relief Valves

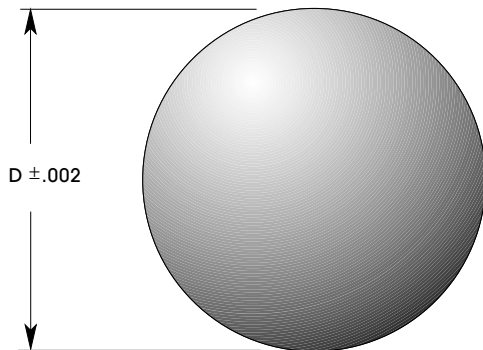

D DIAMETER	CATALOG NUMBER	
	NYLON	TEFLON
1/16	SE1TP-2	---
3/32	SE1TP-3	---
1/8	SE1TP-4	SE3TP-4
3/16	SE1TP-6	SE3TP-6
1/4	SE1TP-8	SE3TP-8
3/8	SE1TP-12	SE3TP-12
1/2	SE1TP-16	SE3TP-16

Sold in Packs of 10

COMPRESSION SPRINGS

302 Stainless Steel Spring Tempered
Length 1/4" thru 2" — OD .057 thru .720

Right Hand Open Wound End Square

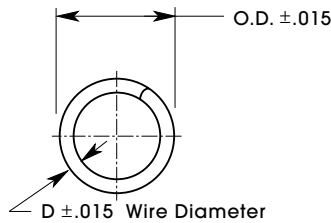
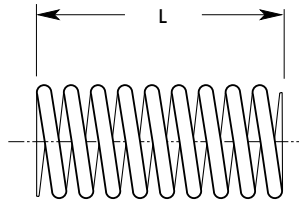

S/R = Spring Rate in Lbs/in

O.D.	D	L	COILS	S/R ±10%	CATALOG NUMBER
.057	.007	3/8	18	1.58	SE1RPS-1
	.008	1/4	13	4.41	SE9RPS-1
	.008	1/2	24	2.08	SE9RPS-2
.088	.010	1/4	9	4.16	SE9RPS-3
	.010	1/2	17	1.91	SE1RPS-2
	.012	3/8	14	5.41	SE9RPS-5
	.012	3/4	24	2.66	SE9RPS-6
.120	.016	1/4	7	14.57	SE9RPS-7
	.016	1/2	13	6.91	SE9RPS-8
	.018	3/8	10	14.91	SE9RPS-9
	.018	5/8	16	8.82	SE1RPS-3
	.018	3/4	19	7.08	SE9RPS-10
	.020	3/8	11	23.07	SE9RPS-11
	.020	3/4	20	10.99	SE9RPS-12
	.022	1/2	14	25.90	SE9RPS-13
	.022	1	27	12.24	SE9RPS-14
	.180	.018	1/2	8	5.58
.018		1	14	2.66	SE9RPS-16
.020		1/2	8	8.08	SE9RPS-17
.020		1	15	3.83	SE9RPS-18
.022		1/2	8	11.82	SE1RPS-4
.022		1	16	5.41	SE9RPS-20

O.D.	D	L	COILS	S/R ±10%	CATALOG NUMBER
.180	.024	1/2	9	15.74	SE9RPS-21
	.024	1	17	7.49	SE9RPS-22
	.026	1/2	9	22.32	SE9RPS-23
	.026	1	17	10.16	SE9RPS-24
	.029	1-1/2	26	10.32	SE9RPS-26
	.032	3/4	14	34.40	SE9RPS-27
.240	.032	1-1/2	27	15.66	SE9RPS-28
	.026	1/2	6	17.40	SE9RPS-29
	.026	5/8	8	10.57	SE1RPS-5
	.026	1	12	6.16	SE9RPS-30
	.035	1/2	8	40.40	SE9RPS-31
	.035	1	14	18.65	SE9RPS-32
	.038	3/4	10	38.40	SE9RPS-33
	.038	1-1/2	20	17.82	SE9RPS-34
	.040	1	14	32.48	SE9RPS-35
	.040	2	27	15.57	SE9RPS-36
.300	.032	5/8	6	5.16	SE1RPS-6
.360	.042	7/8	8	21.24	SE1RPS-7
.420	.045	1	7	16.66	SE1RPS-8
.480	.055	1-1/4	8	22.49	SE1RPS-9
.600	.063	1-1/2	8	19.99	SE1RPS-10
.720	.072	2	9	16.66	SE1RPS-11

EXTENSION SPRINGS

302 Stainless Steel Spring Tempered
Length 1/4" thru 2" — OD .063 thru .360

Full Twist Loops Close Wounds

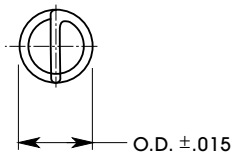
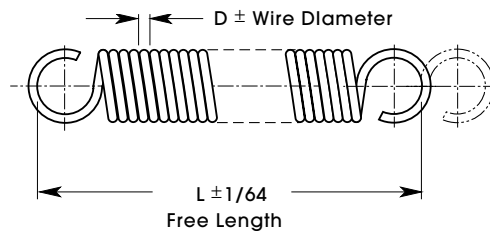

S/R = Spring Rate in Lbs/in

O.D.	D	L	S/R ±10%	CATALOG NUMBER
.063	.008	1/4	1.7	SE10RPS-1
	.008	3/8	.9	SE2RPS-1
	.008	1/2	.6	SE10RPS-2
.093	.010	3/8	1.0	SE10RPS-3
	.012	1/2	1.7	SE2RPS-2
	.010	3/4	.3	SE10RPS-4
.120	.018	1	2.7	SE2RPS-3
.120	.016	3/4	2.5	SE10RPS-5
	.016	1-1/4	1.1	SE10RPS-6
	.020	3/4	6.9	SE10RPS-7
	.020	1-1/4	3.7	SE10RPS-8
.180	.022	3/4	3.6	SE10RPS-9
	.022	1-1/4	1.7	SE10RPS-10
	.026	3/4	22.5	SE10RPS-13
	.031	1-1/4	10.9	SE10RPS-14

O.D.	D	L	S/R ±10%	CATALOG NUMBER
.240	.022	3/4	3.5	SE2RPS-5
.240	.026	3/4	4.7	SE10RPS-15
	.026	1-1/4	1.7	SE10RPS-16
	.029	3/4	8.2	SE10RPS-17
	.029	1-1/4	3.2	SE10RPS-18
	.031	3/4	11.5	SE10RPS-19
	.031	1-1/4	4.4	SE10RPS-20
.360	.034	1-1/4	7.4	SE10RPS-22
	.031	1	2.7	SE10RPS-27
	.037	1	6.6	SE10RPS-29
	.037	1-1/2	2.8	SE10RPS-30
	.045	2	5.2	SE10RPS-32
	.055	1-1/4	32.2	SE10RPS-33

TORSION SPRINGS

Stainless Steel

Pin .109 thru .406 — Length .5 thru 2.00

Left Hand Wound – Right Hand on Request

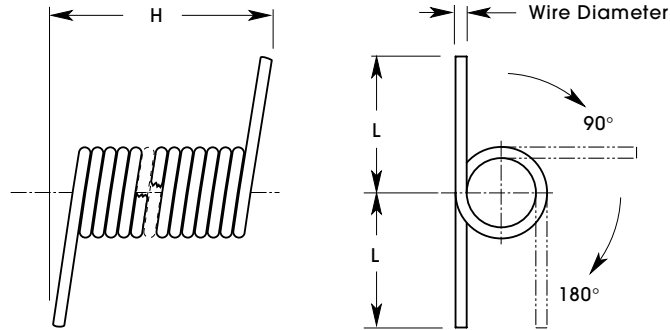
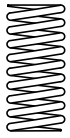

WIRE DIAMETER	OUTSIDE DIAMETER	L	PIN SIZE	H	TORQUE IN.LBS	CATALOG NUMBER
.012	.166	.50	.109	.059	.047	SE3RPS-1
.015	.183	.75	.109	.075	.093	SE3RPS-2
.018	.216	.75	.140	.109	.140	SE3RPS-3
.021	.247	1.00	.156	.127	.218	SE3RPS-4
.025	.304	1.00	.203	.151	.375	SE3RPS-5
.030	.394	1.00	.250	.181	.625	SE3RPS-6
.035	.450	1.25	.281	.212	1.000	SE3RPS-7
.040	.518	2.00	.343	.242	1.375	SE3RPS-8
.048	.618	2.00	.406	.292	2.500	SE3RPS-9

SPRING POST

Carbon Steel – Zinc Plated

Diameters 1/8 • 3/16 • 1/4

QQ-Z-325 Ty. 1-C1.3

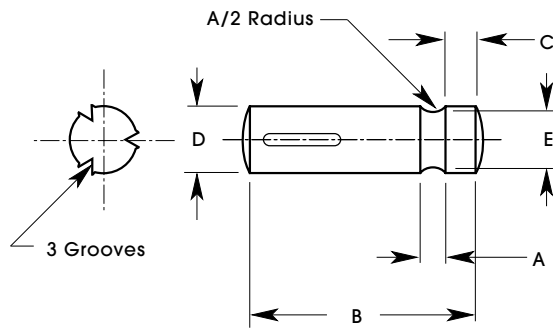

Sold in Pack of 10

D	A	B	E	C	CROWN RADIUS	CROWN HEIGHT	CATALOG NUMBER
1/8	1/16	1/2	.083	1/32	5/32	.013	SELC-1
3/16	1/16	5/8	.125	3/64	1/4	.018	SELC-2
1/4	3/32	3/4	.167	1/16	5/16	.026	SELC-3